

PARTI DI RICAMBIO PER IL TRATTORINO
 SPARE PARTS FOR RIDER-ON-MOWERS
 PIECES DETACHEES POUR TONDEUSE AUTOPORTEE
 RASENTRAKTORERSATZTEILE

TC(P)
TC(P) hydro

INDICE TABLE OF CONTENT	INDEX		INHALT		
	TC 102	TCP 102	TC 102 hy	TCP 102 hy	TCP 122 hy
GRUPPO CARROZZERIA E CHASSIS BODY AND CHASSIS GROUP GROUPE CARROSSERIE ET CHASSIS KARROSSERIE UND GEHÄUSE	001	001	001	001	001
GRUPPO CRUSCOTTO E SEDILE DASHBOARD AND SEAT ASS.Y ENS. TABLEAU COMMANDES ET SIEGE KONSOLE UND SITZ	002	002	002	002	002
GRUPPO STERZO STEERING GROUP GROUPE BARRE DE DIRECTION LENKGETRIEBE	003	003	003	003	003
GRUPPO COMANDO CAMBIO E FRENO GEARBOX AND BRAKE ASS.Y GROUPE BOITE DE VITESSE ET FREIN WECHSEL UND BREMSE SATZ	004	004	-	-	-
GRUPPO COMANDO TRASMISSIONE E FRENO DRIVE AND BRAKE CONTROL UNIT GROUPE COMMANDE TRANSMISSION ET FREIN STEUERUNGSGRUPPE FÜR GETRIEBE UND BREMSE	-	-	004.1	004.1	004.1
GRUPPO MOTORE ENGINE ASS.Y GROUPE MOTEUR MOTORSATZ					
12,5 HP B&S	005	005	005	005	-
16 - 18 HP B&S	005a	005a	005a	005a	005a
15,5 HP B&S	005b	005b	005b	005b	-
20 HP B&S	-	-	-	-	005c
13 HP TECUMSEH	005d	-	005d	-	-
15 HP TECUMSEH	005e	-	005e	-	-
GRUPPO TRASMISSIONE DRIVE UNIT GROUPE TRANSMISSION GETRIEBEGRUPPE	006	006	006.1	006.1	006.1
GRUPPO SOLLEVAMENTO PIATTO CUTTING PLATE LIFTING ASS.Y ENS. SOULEVEMENT PATEAU DE COUPE SCHNEIDWERKZEUG AUFHEBESATZ	007	007	007	007	007
GRUPPO PIATTO DI TAGLIO CUTTING PLATE GROUP GROUPE PATEAU DE COUPE SCHNEIDWERKZEUG					
1	008	008	008	008	008
2	009	009	009	009	009
GRUPPO SOLLEVAMENTO SACCO E MICRO SACCO PIENO LIFTING DEVICE AND EMPTY GRASSCATCHER MICRO GROUPE SOULEVEMENT BAC ET MICRO BAC PLEIN AUSHEBENVORR. UND VOLLKORBEIN RICHTUNG FÜR SACK	-	010	010	010	010
GRUPPO PARTI ELETTRICHE ELECTRICAL PARTS GROUP GROUPE PARTIES ELECTRIQUES ELETRISCHETEILE	011	011	011.1	011.1	011.1
GRUPPO SACCO GRASSCATCHER GROUP GROUPE SAC GRASFANGEINRICHTUNG	012	012	012	012	012
ACCESSORI A RICHIESTA OPTIONALS ON REQUEST ACCESSOIRES SUR DEMANDE ZUBEHOERE NACH ANFRAGE	013	013	013	013	013
SCHEMA ELETTRICO WIRE DIAGRAM SCHEMA ELECTRONIQUE ELEKTRISCHES SCHEMA					
12,5 HP B&S - 13 - 15 HP TECUMSEH	014	014	014.1	014.1	-
15,5 HP B&S	014a	014a	014a.1	014a.1	-
16 - 18 - 20 HP B&S	014b	014b	014b.1	014b.1	014b.1

PARTI DI RICAMBIO PER IL TRATTORINO
 SPARE PARTS FOR RIDER-ON-MOWERS
 PIECES DETACHEES POUR TONDEUSE AUTOPORTEE
 RASENTRAKTORERSATZTEILE

TC(P)
TC(P) hydro

Mod. 1998

001

GRUPPO CARROZZERIA E CHASSIS
 BODY AND CHASSIS GROUP
 GROUPE CARROSSERIE ET CHASSIS
 KARROSSERIE UND GEHÄUSE

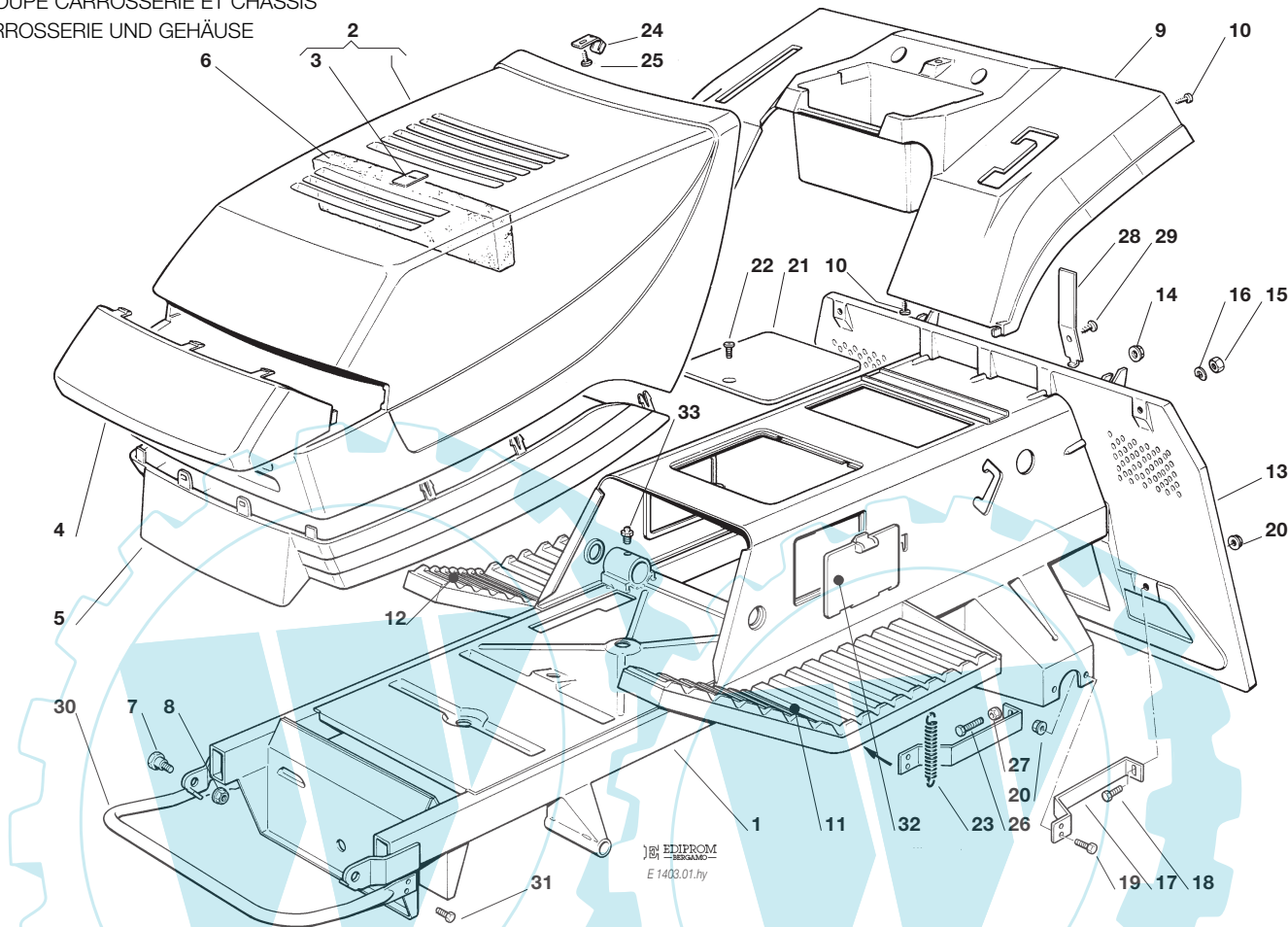

Pos. Nr.	Codice Kodex Code	Descrizione	Description	Description	Beschreibung	Q.tà Q.ty Q.té Menge
1	82800004/7	TELAIO	CHASSIS	CHASSIS	RAHMENSATZ	1
	82800023/0	TELAIO (hydro)	CHASSIS (hydro)	CHASSIS (hydro)	RAHMENSATZ (hydro)	1
2	☛	COFANO SUPER. (TC)	UPPER ENGINE HOOD (TC)	CAPOT SUPERIEURE (TC)	OBERHAUBESATZ (TC)	1
	82076801/1	ROSSO	RED	ROUGE	ROT	
	82076804/0	VERDE	GREEN	VERT	GRÜN	
	82076805/0	GIALLO	YELLOW	JAUNE	GELB	
	82076807/0	BLU	BLUE	BLEU	BLAU	
	☛	COFANO SUPER. (TCP)	UPPER ENGINE HOOD (TCP)	CAPOT SUPERIEURE (TCP)	OBERHAUBESATZ (TCP)	1
	82076840/0	ROSSO	RED	ROUGE	ROT	
	82076842/0	VERDE	GREEN	VERT	GRÜN	
	82076844/0	GIALLO	YELLOW	JAUNE	GELB	
	82076846/0	BLU	BLUE	BLEU	BLAU	
3	☛	PIASTRINA (TC)	PLATE (TC)	PLAQUE (TC)	PLATTE (TC)	1
	25547016/1	ROSSA	RED	ROUGE	ROT	
	25547015/0	VERDE	GREEN	VERT	GRÜN	
	25547014/0	GIALLA	YELLOW	JAUNE	GELB	
	25547024/0	BLU	BLUE	BLEU	BLAU	
	☛	PIASTRINA (TCP)	PLATE (TCP)	PLAQUE (TCP)	PLATTE (TCP)	1
	25547025/0	ROSSA	RED	ROUGE	ROT	
	25547026/0	VERDE	GREEN	VERT	GRÜN	
	25547027/0	GIALLA	YELLOW	JAUNE	GELB	
	25547028/0	BLU	BLUE	BLEU	BLAU	
4	25410858/0	MASCHERINA (TC)	GRILL (TC)	PANNEAU (TC)	SCHUTZ (TC)	1
	25410860/0	MASCHERINA DX (TCP)	RIGHT GRILL (TCP)	PANNEAU DROITE (TCP)	RECHTE SCHUTZ (TCP)	1
	25410861/0	MASCHERINA SX (TCP)	LEFT GRILL (TCP)	PANNEAU GAUCHE (TCP)	LINKE SCHUTZ (TCP)	1

Pos. Nr.	Codice Kodex Code	Descrizione	Description	Description	Beschreibung	Q.tà Q.ty Q.té Menge
5	25076802/0	COFANO INFERIORE (TC)	LOWER ENGINE HOOD (TC)	CAPOT INFERIEURE (TC)	UNTERHAUBESATZ (TC)	1
	25076808/0	COFANO INFERIORE (TCP)	LOWER ENGINE HOOD (TCP)	CAPOT INFERIEURE (TCP)	UNTERHAUBESATZ (TCP)	1
6	25730000/0	SEPARATORE ASPIRAZ. (TC - 13-15 HP TECUMSEH)	INTAKE SEPARATOR (TC - 13-15 HP TECUMSEH)	SEPARATEUR ASPIRATIONS (TC - 13-15 HP TECUMSEH)	AUGENABSCHIEDER (TC - 13-15 HP TECUMSEH)	1
	25730002/0	SEPARATORE ASPIRAZ. (TCP - 15,5-16-18 HP B&S)	INTAKE SEPARATOR (TCP - 15,5-16-18 HP B&S)	SEPARATEUR ASPIRATIONS (TCP - 15,5-16-18 HP B&S)	AUGENABSCHIEDER (TCP - 15,5-16-18 HP B&S)	1
7	25510015/1	PERNO	PIN	PIVOT	BOLZEN	2
8	12293201/0	DADO	NUT	ECROU	MUTTER	2
9	←	COPERTURA RUOTE (TC)	WHEELS COVER (TC)	COUVRE-ROUES (TC)	RADENKAPPE (TC)	1
	25110157/1	ROSSA	RED	ROUGE	ROT	
	25110159/0	VERDE	GREEN	VERT	GRÜN	
	25110161/0	GIALLO	YELLOW	JAUNE	GELB	
	25110163/0	BLU	BLUE	BLEU	BLAU	
	←	COPERTURA RUOTE (TCP)	WHEELS COVER (TCP)	COUVRE-ROUES (TCP)	RADENKAPPE (TCP)	1
	25110170/0	ROSSA	RED	ROUGE	ROT	
	25110171/0	VERDE	GREEN	VERT	GRÜN	
	25110172/0	GIALLO	YELLOW	JAUNE	GELB	
	25110173/0	BLU	BLUE	BLEU	BLAU	
10	12735402/0	VITE	SCREW	VIS	SCHRAUBE	4
11	25110260/1	COPRIPEDANA SX	LEFT FOOTBOARD COVER	COUVRE MARCHEPIED GAUCHE	LINKE FUSSBRETTDECKEL	1
12	25110261/1	COPRIPEDANA DX	RIGHT FOOTBOARD COVER	COUVRE MARCHEPIED DROITE	RECHTE FUSSBRETTDECKEL	1
13	82547001/3	PIASTRA POST.	REAR PLATE	PLAQUE POSTERIEURE	HINTERPLATTE	1
14	12293201/0	DADO	NUT	ECROU	MUTTER	5
15	12295200/0	DADO	NUT	ECROU	MUTTER	2
16	12585100/0	GROWER	GROWER	GROWER	GROWER	2
17	25650021/0	RINFORZO PIASTRA POST.	REAR PLATE STIFFENING	RENFORCEMENT PLAQUE POST.	HINTERPLATTEVERSTA- ERKUNG	2
18	12793102/0	VITE (TC)	SCREW (TC)	VIS (TC)	SCHRAUBE (TC)	2
18	12793102/0	VITE (TCP)	SCREW (TCP)	VIS (TCP)	SCHRAUBE (TCP)	1
19	12793102/0	VITE	SCREW	VIS	SCHRAUBE	2
20	12293201/0	DADO	NUT	ECROU	MUTTER	4
21	82597120/0	PORTINA	HANDHOLE	GRILLE	GITTER	1
22	12728440/0	VITE	SCREW	VIS	MUTTER	1
23	25430218/0	MOLLA	SPRING	RESSORT	FEDER	2
24	25430217/0	MOLLA AGGANCIAMENTO (TCP)	COUPLING SPRING (TCP)	RESSORT ACCROCHA (TCP)	GEKUPPLUNGSFEDER (TCP)	2
25	12728099/0	VITE (TCP)	SCREW (TCP)	VIS (TCP)	SCHRAUBE (TCP)	2
26	12691100/0	VITE (TCP)	SCREW (TCP)	VIS (TCP)	SCHRAUBE (TCP)	1
27	12293201/0	DADO (TCP)	NUT (TCP)	ECROU (TCP)	MUTTER (TCP)	1
28	25430228/0	MOLLA	SPRING	RESSORT	FEDER	1
29	12728440/0	VITE	SCREW	VIS	SCHRAUBE	1
30	82869006/0	PROTEZIONE SILENZIATORE	MUFFLER PROTECTION	PROTECTION SILENCIEUX	AUSPUFFSCHUTZ	1
31	12734995/0	VITE	SCREW	VIS	SCHRAUBE	4
32	25597121/0	PORTINA (hydro)	HANDHOLE (hydro)	GRILLE (hydro)	GITTER (hydro)	2
33	12379511/0	INGRASSATORE (hydro)	GREASE DISPENSER (hydro)	GRAISSEUR (hydro)	FETTBÜCHSE (hydro)	1

PARTI DI RICAMBIO PER IL TRATTORINO
 SPARE PARTS FOR RIDER-ON-MOWERS
 PIECES DETACHEES POUR TONDEUSE AUTOPORTEE
 RASENTRAKTORERSATZTEILE

TC(P)
TC(P) hydro

Mod. 1998

002

GRUPPO CRUSCOTTO E SEDILE
 DASHBOARD AND SEAT ASS.Y
 ENS. TABLEAU COMMANDES ET SIEGE
 KONSOLE UND SITZ

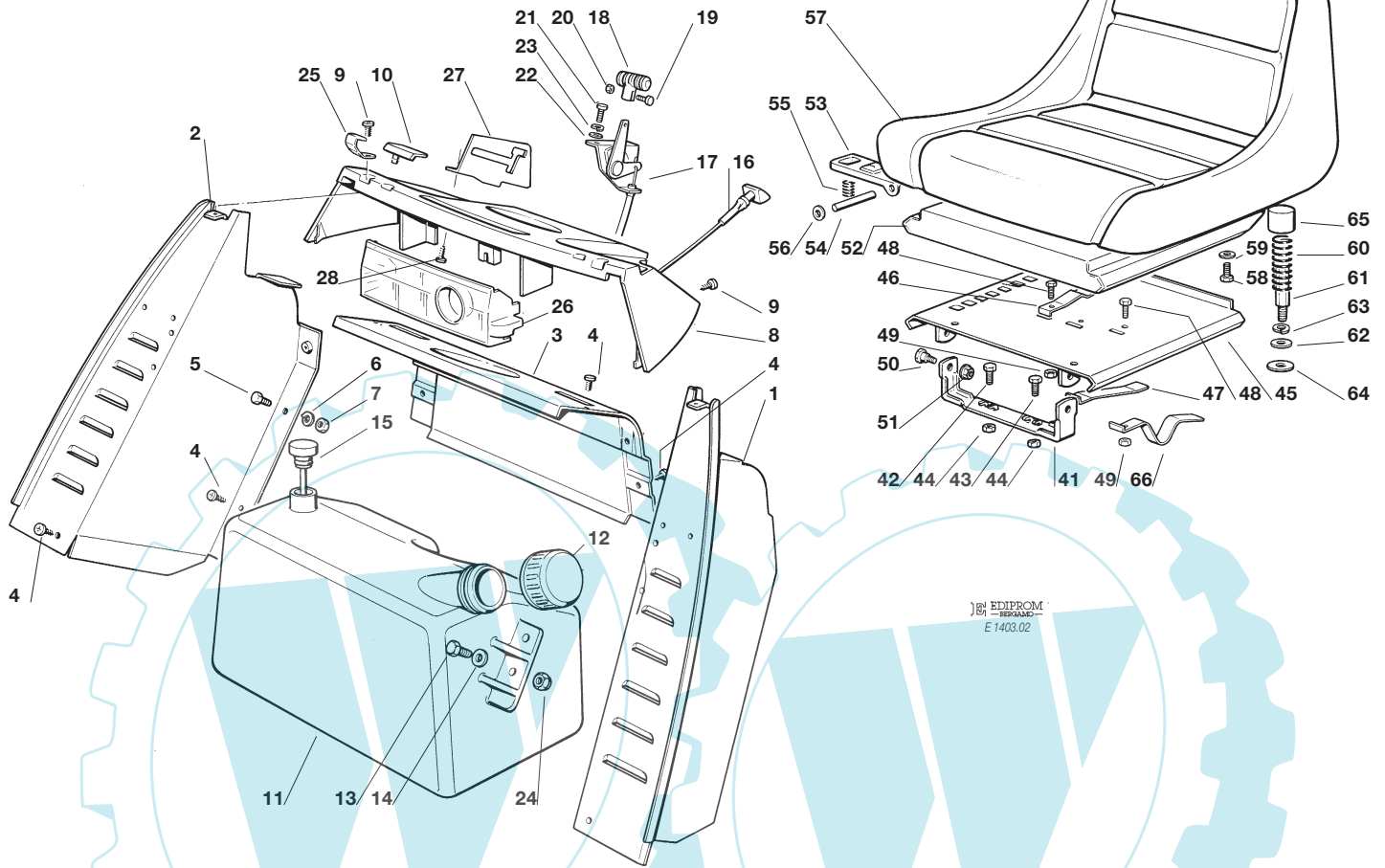

Pos. Nr.	Codice Kodex Code	Descrizione	Description	Description	Beschreibung	Q.tà Q.ty Q.té Menge
1	82785021/3	SUPP. CRUSCOTTO SX	LEFT DASHBOARD SUPP.	SUPPORT TABLEAU GAUCHE	LINKER KONSOLEHALTER	1
2	82785022/2	SUPP. CRUSCOTTO DX	RIGHT DASHBOARD SUPP.	SUPPORT TABLEAU DROITE	RECHTER KONSOLEHALTER	1
3	82785023/0	SUPP. CRUSCOTTO CENTR.	CENTRAL DASHBOARD SUPP.	SUPPORT TABLEAU CENTRAL	ZENTRALER KONSOLE HALTER	1
4	12728440/0	VITE	SCREW	VIS	SCHRAUBE	8
5	12790780/0	VITE	SCREW	VIS	SCHRAUBE	2
6	12582100/0	GROWER	GROWER	GROWER	GROWER	2
7	12292100/0	DADO	NUT	ECROU	MUTTER	2
8	25120149/0	CRUSCOTTO (TC)	DASHBOARD (TC)	TABLEAU DE BORD (TC)	KONSOLE (TC)	1
	25120150/0	CRUSCOTTO (TCP)	DASHBOARD (TCP)	TABLEAU DE BORD (TCP)	KONSOLE (TCP)	1
	25120155/0	CRUSCOTTO (TC hydro)	DASHBOARD (TC hydro)	TABLEAU DE BORD (TC hy.)	KONSOLE (TC hydro)	1
	25120153/0	CRUSCOTTO (TCP hydro)	DASHBOARD (TCP hydro)	TABLEAU DE BORD (TCP hy.)	KONSOLE (TCP hydro)	1
9	12728440/0	VITE	SCREW	VIS	SCHRAUBE	4
10	25260000/0	GOMMINO	GROMMET	PROTECTION	SCHUTZ	2
11	25735110/1	SERBATOIO (12,5 - 15,5 HP B&S 13 - 15 HP TECUMSEH)	TANK (12,5 - 15,5 HP B&S 13 - 15 HP TECUMSEH)	RESERVOIR (12,5 - 15,5 HP B&S 13 - 15 HP TECUMSEH)	TANK (12,5 - 15,5 HP B&S 13 - 15 HP TECUMSEH)	1
	25735111/1	SERBATOIO (16 - 18 - 20 HP B&S)	TANK (16 - 18 - 20 HP B&S)	RESERVOIR (16 - 18 - 20 HP B&S)	TANK (16 - 18 - 20 HP B&S)	1
12	25795000/0	TAPPO	CAP	BOUCHON	TANKVERSCHLUSS	1
13	12788910/0	VITE	SCREW	VIS	SCHRAUBE	2
14	12523020/0	RONDELLA	WASHER	RONDELLE	SCHEIBE	2
15	25290000/0	INDICATORE LIVELLO (16 - 18 - 20 HP B&S)	FUEL LEVEL INDICATOR (16 - 18 - 20 HP B&S)	INDICATEUR NIVEAU (16 - 18 - 20 HP B&S)	KRAFTSTOFFMESSER (16 - 18 - 20 HP B&S)	1
16	25090000/0	COMANDO STARTER (16 - 18 - 20 HP B&S)	STARTER DRIVE (16 - 18 - 20 HP B&S)	COMMANDE STARTER (16 - 18 - 20 HP B&S)	STARTER BETAETIGUNG (16 - 18 - 20 HP B&S)	1

Pos. Nr.	Codice Kodex Code	Descrizione	Description	Description	Beschreibung	Q.tà Q.ty Q.té Menge
17	82000200/1	ACCELERATORE 12,5 - 15,5 HP B&S 13 - 15 HP TECUMSEH	ACCELERATOR 12,5 - 15,5 HP B&S 13 - 15 HP TECUMSEH	ACCELERATEUR 12,5 - 15,5 HP B&S 13 - 15 HP TECUMSEH	GAS ZUG 12,5 - 15,5 HP B&S 13 - 15 HP TECUMSEH	1
	82000201/1	ACCELERATORE 16 - 18 HP B&S	ACCELERATOR 16 - 18 HP B&S	ACCELERATEUR 16 - 18 HP B&S	GAS ZUG 16 - 18 HP B&S	1
18	25394501/0	MANOPOLA	HANDLE	POIGNE	GRIFF	1
19	12726388/0	VITE	SCREW	VIS	SCHRAUBE	1
20	12290800/0	DADO	NUT	ECROU	MUTTER	1
21	12788512/0	VITE	SCREW	VIS	SCHRAUBE	2
22	12521310/0	RONDELLA	WASHER	RONDELLE	SCHEIBE	2
23	12581200/0	GROWER	GROWER	GROWER	GROWER	2
24	12154330/0	DADO	NUT	ECROU	MUTTER	2
25	25430215/0	MOLLA AGGANCIO (TC)	COUPLING SPRING (TC)	RESSORT ACCROCHAGE (TC)	KUPPLUNGSFEDER	2
26	25600010/0	PROTEZIONE SCHEDA	CARD PROTECTION	PROTECTION DE CARTE	KARTESCHUTZ	1
27	25774235/0	STAFFA GUIDA	PLATE	ETRIER	BRIDE	1
28	12727810/0	VITE	SCREW	VIS	SCHRAUBE	3
41	82774207/0	STAFFA SUPP. SEDILE	SEAT CLAMP SUPPORT	ETRIER SUPPORT SIEGE	BRIDE F. SITZHALTER	1
42	12793500/0	VITE	SCREW	VIS	SCHRAUBE	1
43	12792611/0	VITE	SCREW	VIS	SCHRAUBE	1
44	12293201/0	DADO	NUT	ECROU	MUTTER	2
45	82785089/0	SUPP. SEDILE FISSO	FIXED SEAT SUPP.	SUPPORT SIEGE FIXE	FEST SITZHALTER	1
46	25430203/0	MOLLA ARRESTO	SPRING	RESSORT D'ARRET	RASTFEDER	1
47	25430224/0	MOLLA COMANDO	SPRING	RESSORT DE COMMANDE	FEDER	1
48	12789000/0	VITE	SCREW	VIS	SCHRAUBE	3
49	12154330/0	DADO	NUT	ECROU	MUTTER	3
50	22524970/1	PERNO	PIN	PIVOT	BOLZEN	2
51	12293201/0	DADO	NUT	ECROU	MUTTER	2
52	82785087/0	SUPPORTO SEDILE	SEAT SUPPORT	SUPPORT SIEGE	SITZHALTER	1
53	25318109/0	LEVA ARRESTO	STOP LEVER	LEVIER D'ARRET	ABSTELLHEBEL	1
54	25510000/0	PERNO	PIN	PIVOT	BOLZEN	1
55	25430202/0	MOLLA	SPRING	RESSORT	FEDER	1
56	12604897/0	RONDELLA	WASHER	RONDELLE	SCHEIBE	2
57	25722450/0	SEDILE (TC)	SEAT (TC)	SIEGE (TC)	SITZ (TC)	1
	25722451/1	SEDILE (TCP)	SEAT (TCP)	SIEGE (TCP)	SITZ (TCP)	1
58	12793101/0	VITE	SCREW	VIS	SCHRAUBE	4
59	12583500/0	GROWER	GROWER	GROWER	GROWER	4
60	25430205/0	MOLLA	SPRING	RESSORT	FEDER	2
61	25510016/0	PERNO	PIN	PIVOT	BOLZEN	2
62	12521350/0	RONDELLA	WASHER	RONDELLE	SCHEIBE	2
63	12583500/0	GROWER	GROWER	GROWER	GROWER	2
64	12523070/0	RONDELLA	WASHER	RONDELLE	SCHEIBE	2
65	25122000/0	CUFFIA PROTEZ.	HOOD	PROTECTEUR	SCHUTZKASTEN	2
66	25430223/0	MOLLA	SPRING	RESSORT	FEDER	1

PARTI DI RICAMBIO PER IL TRATTORINO
 SPARE PARTS FOR RIDER-ON-MOWERS
 PIECES DETACHEES POUR TONDEUSE AUTOPORTEE
 RASENTRAKTORERSATZTEILE

TC(P)
TC(P) hydro

Mod. 1998

003

GRUPPO STERZO
 STEERING GROUP
 GROUPE BARRE DE DIRECTION
 LENKGETRIEBE

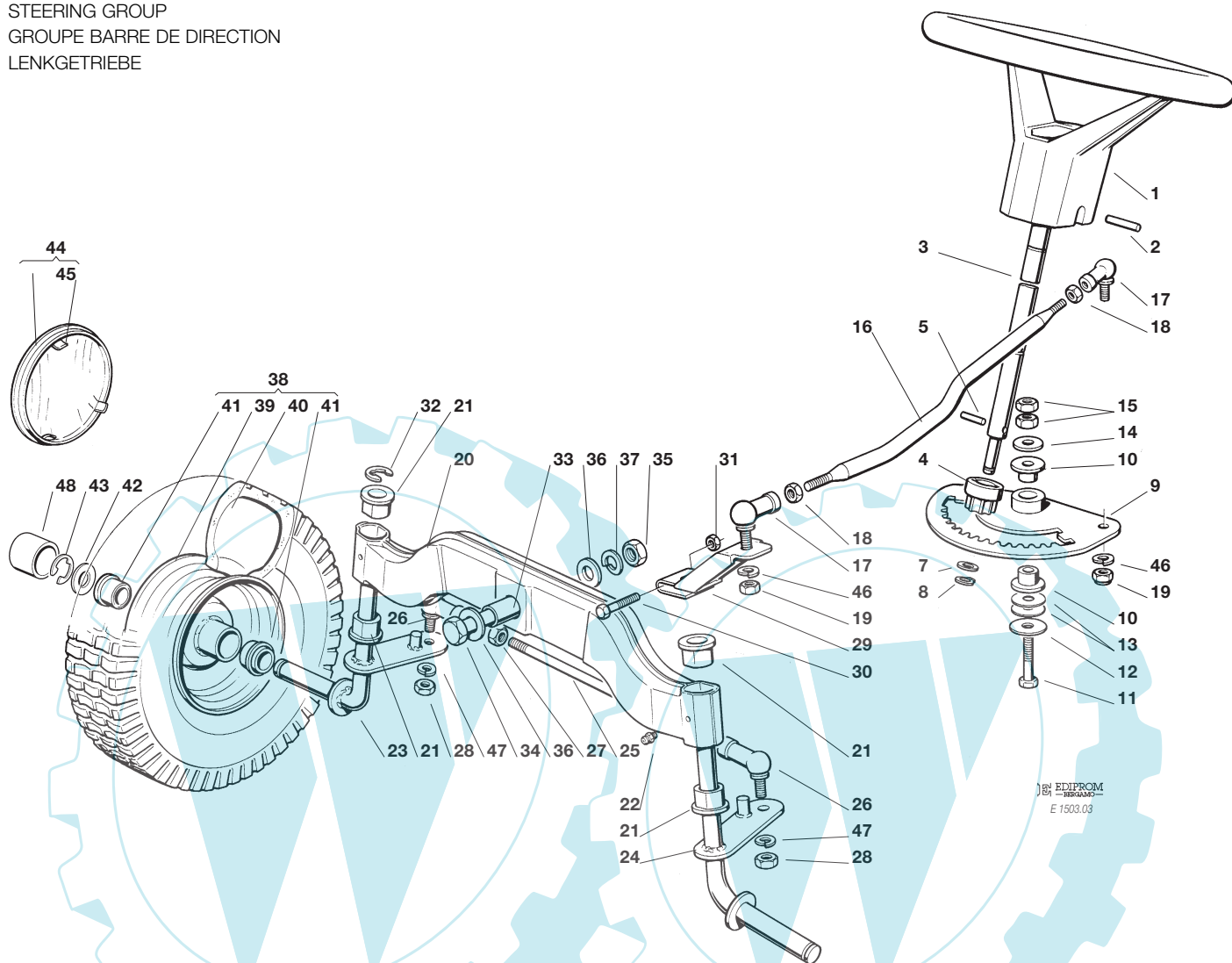

Pos. Nr.	Codice Kodex Code	Descrizione	Description	Description	Beschreibung	Q.tà Q.ty Q.té Menge
1	25961200/0	VOLANTE	STEERING WHEEL	VOLANT	LENKRAD	1
2	12620299/0	SPINA	PIN	GOUPILLE	STIFT	1
3	25520002/0	PIANTONE	STEERING COLUMN	TUBE DE DIRECTION	LENKUNGSAEULE	1
4	25570000/0	PIGNONE	PINION	PIGNON	RITZEL	1
5	12622650/0	SPINA	PIN	GOUPILLE	STIFT	1
7	12521370/0	RONDELLA	WASHER	RONDELLE	SCHEIBE	1
8	12436030/0	PIASTRINA	PLATE	PLAQUETTE	PLATTECHEN	1
9	82735504/0	SETTORE STERZO	STEERING SHAFT	ARBRE DIRECTION	LENKUNGSWELLE	1
10	25160001/0	BRONZINA	BRASS	COUSSINET	BÜCHSE	2
11	12692420/0	VITE	SCREW	VIS	SCHRAUBE	1
12	12523090/0	RONDELLA	WASHER	RONDELLE	SCHEIBE	1
13	22672150/0	RONDELLA	WASHER	RONDELLE	SCHEIBE	2
14	25670002/0	RONDELLA	WASHER	RONDELLE	SCHEIBE	1
15	12295200/0	DADO	NUT	ECROU	MUTTER	2
16	25033003/1	ASTA COMANDO STERZO	STEERING ROD	LEVIER BARRE DE DIRECTION	LENKUNGSSTAB	1
17	22746600/0	SNODO M10	JOINT M10	JOINT M10	GELENK M10	2
18	12295200/0	DADO	NUT	ECROU	MUTTER	2
19	12295200/0	DADO	NUT	ECROU	MUTTER	2
20	82034001/1	BILANCIERE COMPLETO DI BRONZINA ED INGRASSATORE	EQUALIZER WITH BUSH AND LUBRICATOR	BALANCIER AVEC COUSSINET ET GRAISSEUR	KIPPEBEL MIT BRONZE-LAGER UND FETTBUCHSE	1

Pos. Nr.	Codice Kodex Code	Descrizione	Description	Description	Beschreibung	Q.tà Q.ty Q.té Menge
21	25034002/0	BRONZINA	BRASS	COUSSINET	BÜCHSE	4
22	12379511/0	INGRASSATORE	GREASE DISPENSER	GRAISSEUR	FETTBUCHSE	2
23	82230349/0	FUSELLO DX	R. STUB AXLE	FUSEAU DROITE	RECHTER ACHSSCHENKEL	1
24	82230348/0	FUSELLO SX	L. STUB AXLE	FUSEAU GAUCHE	LINKER ACHSSCHENKEL	1
25	25840001/0	TIRANTE	TIE ROD	TIRANT	KUPPLUNG	1
26	22746600/0	SNODO M10	JOINT M10	JOINT M10	GELENK M10	2
27	12295200/0	DADO	NUT	ECROU	MUTTER	2
28	12295200/0	DADO	NUT	ECROU	MUTTER	2
29	82318101/0	ASS. LEVA COMANDO	LEVER ASS.Y	ENSEMBLE LEVIER	HEBEL	1
30	12691700/0	VITE	SCREW	VIS	SCHRAUBE	1
31	12155000/0	DADO	NUT	ECROU	MUTTER	1
32	12001000/0	ANELLO ELASTICO	SNAP RING	ANNEAU RESSORT	SPRENGRING	1
33	25160005/0	DISTANZIALE	SPACER	ENTRETOISE	ENTFERNUNGSSTUECK	1
34	12694100/0	VITE	SCREW	VIS	SCHRAUBE	1
35	12295800/0	DADO	NUT	ECROU	MUTTER	1
36	12521390/0	RONDELLA	WASHER	RONDELLE	SCHEIBE	2
37	12587900/0	GROWER	GROWER	GROWER	GROWER	1
38	82680002/0	RUOTA COMPLETA CON CUSCINETTI (TURF-SAVER)	WHEEL ASS.Y WITH BEARINGS (TURF-SAVER)	ENSEMBLE ROUE AVEC ROULEM. (TURF-SAVER)	VORDERRAD MIT KUGEL LAGER (TURF-SAVER)	2
39	82000590/0	CERCHIO RUOTA ANT.	FRONT RIMM	BANDAGE ROUE ANT.	VORDERRAD FELGER	2
40	25590000/0	PNEUMATICO (TURF-SAVER)	SHOE (TURF-SAVER)	PNEU (TURF-SAVER)	REIFEN (TURF-SAVER)	2
41	25122200/1	CUSCINETTO	BEARING	ROULEMENT	LAGER	4
42	25670005/1	RONDELLA SPESSORE 2,5 MM	WASHER THICKNEE 2.5 MM	RONDELLE EPAISSEUR 2,5 MM	SCHEIBE DICKE 2,5 MM	2
43	12001000/0	ANELLO ELASTICO	SNAP RING	ANNEAU RESSORT	SPRENGRING	2
44	82110250/1	ASS. COPRIDISCO RUOTA ANTERIORE (TC)	FRONT WHEEL COVERENS. ASS.Y (TC)	COUVRE DISQUE ROUE ANTERIEURE (TC)	VORRDERRAD DECKEL (TC)	2
	82110252/0	ASS. COPRIDISCO RUOTA ANTERIORE (TCP)	FRONT WHEEL COVERENS. ASS.Y (TCP)	COUVRE DISQUE ROUE ANTERIEURE (TCP)	VORRDERRAD DECKEL (TCP)	2
45	25430209/0	MOLLA AGGANCIO	SPRING	RESSORT	FEDER	8
46	12585100/0	GROWER	GROWER	GROWER	GROWER	2
47	12585100/0	GROWER	GROWER	GROWER	GROWER	2
48	22110230/0	COPRIMOZZO	HUB COVER	COUVRE MOYEU	RADNABE DECKEL	2

PARTI DI RICAMBIO PER IL TRATTORINO
 SPARE PARTS FOR RIDER-ON-MOWERS
 PIECES DETACHEES POUR TONDEUSE AUTOPORTEE
 RASENTRAKTORERSATZTEILE

TC(P)

GRUPPO COMANDO CAMBIO E FRENO
 GEARBOX AND BRAKE ASS.Y
 GROUPE BOITE DE VITESSE ET FREIN
 WECHSEL UND BREMSE SATZ

Mod. 1998

004

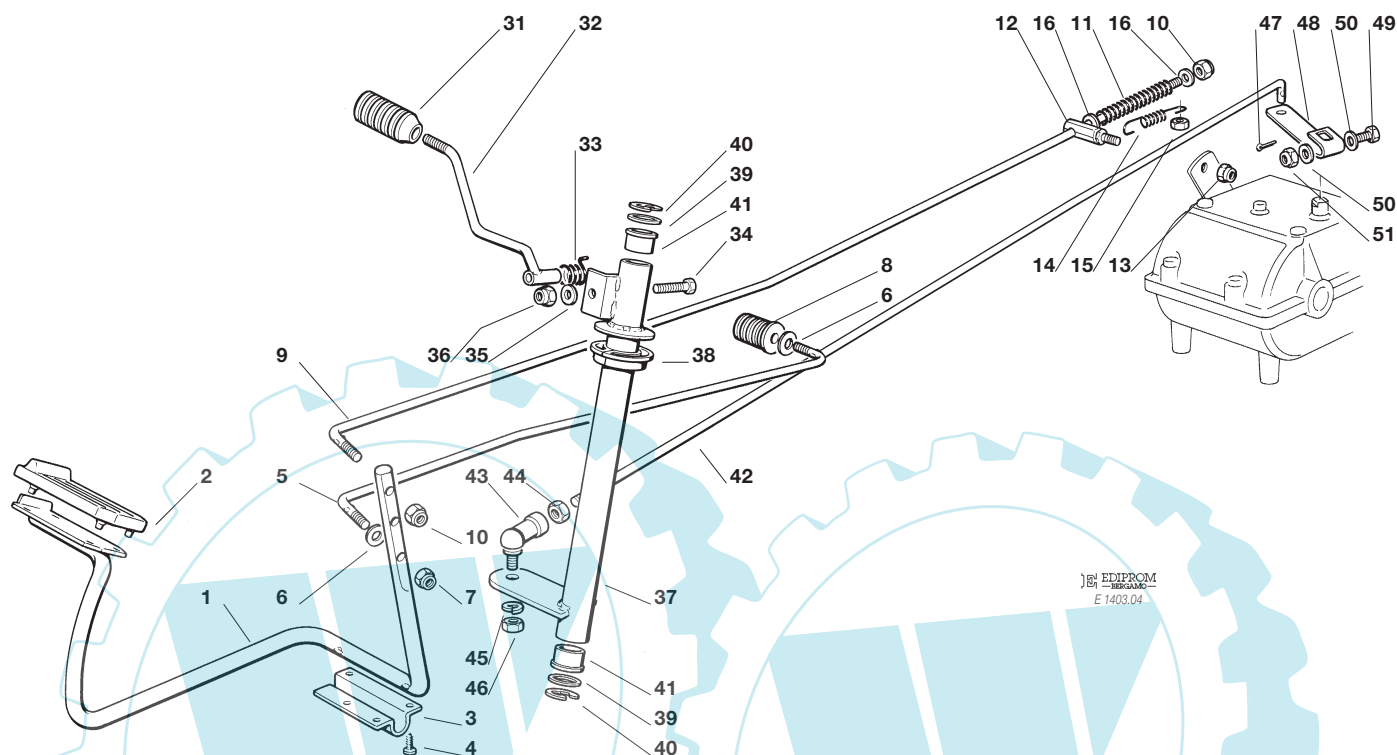

Pos. Nr.	Codice Kodex Code	Descrizione	Description	Description	Beschreibung	Q.tà Q.ty Q.té Menge
1	82500001/0	PEDALE FRENO	BRAKE PEDAL	PEDALE DE FREIN	BREMSPEDAL	1
2	25110269/0	COPRISTAFFA	CLAMP COVER	COUVRE ETRIER	BRIDEDECKEL	1
3	25547012/0	PIASTRINA	PLATE	PLAQUE	PLATTE	1
4	12731601/0	VITE	SCREW	VIS	SCHRAUBE	4
5	25033005/0	ASTA	ROD	BARRE	STANGE	1
6	12523060/0	RONDELLA	WASHER	RONDELLE	SCHEIBE	2
7	12155000/0	DADO	NUT	ECROU	MUTTER	1
8	82394500/0	MANOPOLA FRENO	BRAKE KNOB	POIGNEE DE FREIN	BREMSEKNOPF	1
9	25033007/0	ASTA COMANDO FRENO	BRAKE CONTROL ROD	TIGE CONTROLE FREIN	BREMSE KONTROLLESATZ	1
10	12154510/0	DADO	NUT	ECROU	MUTTER	2
11	25430212/1	MOLLA	SPRING	RESSORT	FEDER	1
12	25510017/0	PERNO	PIN	PIVOT	BOLZEN	1
13	12155000/0	DADO	NUT	ECROU	MUTTER	1
14	25430213/0	MOLLA RICHIAMO FRENO	SPRING BRAKE	RESSORT FREIN	FEDER BREMSE	1
15	12155000/0	DADO	NUT	ECROU	MUTTER	1
16	12521330/0	RONDELLA	WASHER	RONDELLE	SCHEIBE	2
31	82394506/0	MANOPOLA CAMBIO	GEARBOX KNOB	POIGNEE BOITE DE VITESSE	WECHSELGETRIEBE	1
32	82318130/0	LEVA COMANDO CAMBIO	GEARSHIFT	LEVIER CHANGEMENT VITESSE	DEGETRIEBE HEBEL	1
33	25430225/0	MOLLA	SPRING	RESSORT	FEDER	1
34	12689515/0	VITE	SCREW	VIS	SCHRAUBE	1
35	12521330/0	RONDELLA	WASHER	RONDELLE	SCHEIBE	1
36	12154510/0	DADO	NUT	ECROU	MUTTER	1

Pos. Nr.	Codice Kodex Code	Descrizione	Description	Description	Beschreibung	Q.tà Q.ty Q.té Menge
37	82869005/0	TUBO COMANDO	SPEED DRIVE TUBE	TUBE COMMANDE CHANGE- MENT DE VITESSE	GAENGESCHALTUNG ROHR	1
38	25040602/0	BUSSOLA	BUSH	DOUILLE	BÜCHSE	2
39	25670006/0	RONDELLA	WASHER	RONDELLE	SCHEIBE	2
40	12001000/0	SEEGER	SEEGER	SEEGER	SEEGER	2
41	25040601/0	BUSSOLA	BUSH	DOUILLE	BÜCHSE	2
42	25033004/0	ASTA	ROD	BARRE	STANGE	1
43	22746601/0	SNODO M8	JOINT M8	JOINT M8	GELENK M8	1
44	12293200/0	DADO	NUT	ECROU	MUTTER	1
45	12583500/0	GROWER	GROWER	GROWER	GROWER	1
46	12293200/0	DADO	NUT	ECROU	MUTTER	1
47	12141418/0	COPPIGLIA	COTTER PIN	GOUPILLE	SPLIT	
48	25318117/0	LEVA CAMBIO	GEARSHIFT	LEVIER CHANGEMENT DE VITESSE	GETRIEBE HEBEL	1
49	12689500/0	VITE	SCREW	VIS	SCHRAUBE	1
50	12521330/0	RONDELLA	WASHER	RONDELLE	SCHEIBE	2
51	12154510/0	DADO	NUT	ECROU	MUTTER	1

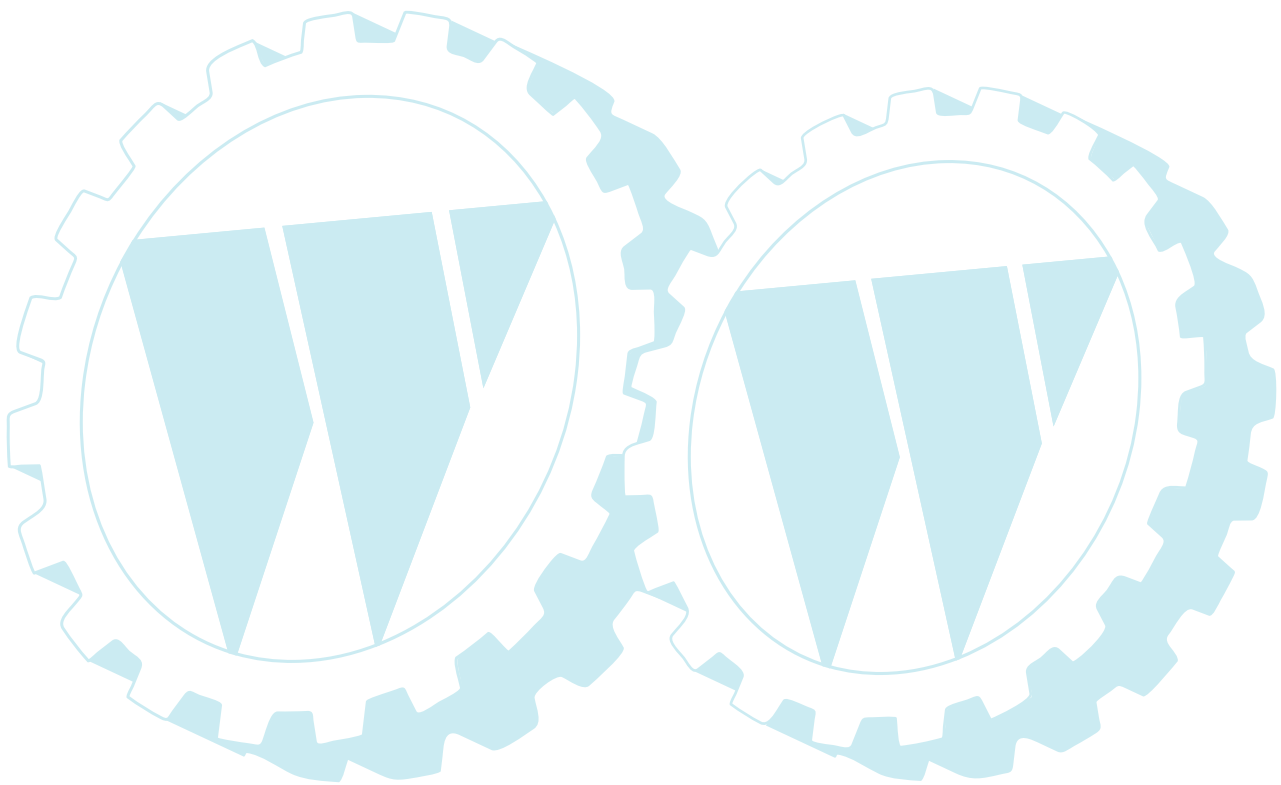

PARTI DI RICAMBIO PER IL TRATTORINO
 SPARE PARTS FOR RIDER-ON-MOWERS
 PIECES DETACHEES POUR TONDEUSE AUTOPORTEE
 RASENTRAKTORERSATZTEILE

TC(P) hydro

GRUPPO COMANDO TRASMISSIONE E FRENO
 DRIVE AND BRAKE CONTROL UNIT
 GROUPE COMMANDE TRANSMISSION ET FREIN
 STEUERUNGSGRUPPE FÜR GETRIEBE UND BREMSE

Mod. 1998 **004.1**

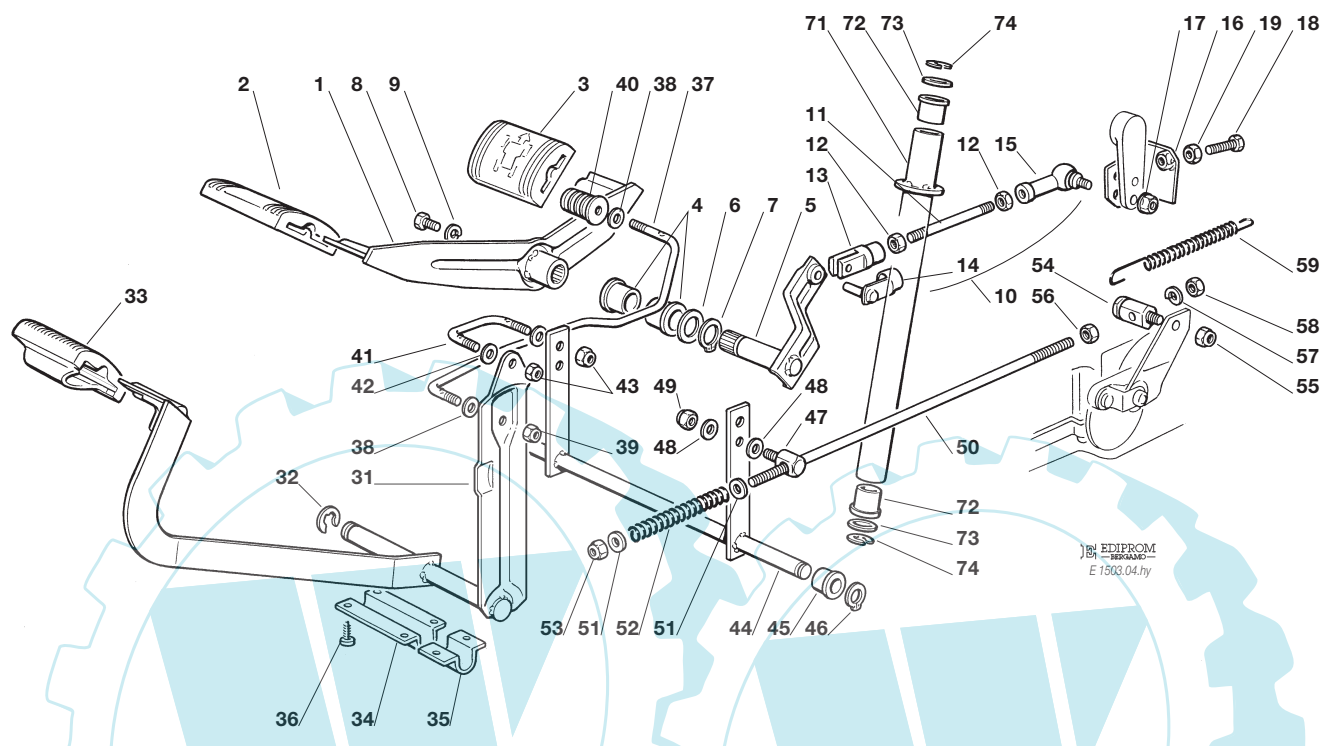

Pos. Nr.	Codice Kodex Code	Descrizione	Description	Description	Beschreibung	Q.tà Q.ty Q.té Menge
1	8250004/0	PEDALE AVANZAMENTO	DRIVE PEDAL	PEDALE TRANSMISSION	GETRIEBEPEDAL	1
2	25110265/0	COPRISTAFFA ANTERIORE	CLAMP COVER FRONT	COUVRE ETRIER AVANT	BRIDEDECKEL VORDE	1
3	25110266/0	COPRISTAFFA POSTERIORE	CLAMP COVER REAR	COUVRE ETRIER ARRIERE	BRIDEDECKEL HINTER	1
4	25034002/0	BRONZINA	BUSH	DOUILLE	BÜCHSE	2
5	82318145/0	LEVA	LEVER	LEVIER	HEBEL	1
6	22672153/0	RONDELLA	WASHER	RONDELLE	SCHEIBE	1
7	12609260/0	SEEGER	SEEGER	SEEGER	SEEGER	1
8	12792612/0	VITE	SCREW	VIS	SCHRAUBE	1
9	12583501/0	GROWER	GROWER	GROWER	GROWER	1
10	82820002/0	ASSIEME TIRANTE (11÷15)	ROD ASS.Y (11÷15)	ENS. BARRE (11÷15)	STANGE KOMPLETT (11÷15)	1
11	25598002/0	TIRANTE	ROD	BARRE	STANGE	1
12	12293200/0	DADO	NUT	ECROU	MUTTER	2
13	18399001/0	FORCELLA	FORK	FOURCHE	GABEL	1
14	18210201/0	CLIP	CLIP	CLIP	SPERRBOLZEN	1
15	22746602/0	SNODO	JOINT	JOINT	GELENK	1
16	82774217/0	STAFFA	BRACKET	ETRIER	BRIDE	1
17	12293201/0	DADO	NUT	ECROU	MUTTER	1
18	12793701/0	VITE	SCREW	VIS	SCHRAUBE	1
19	12293200/0	DADO	NUT	ECROU	MUTTER	1
31	8250006/0	PEDALE FRENO	BRAKE PEDAL	PEDALE DE FREIN	BREMSPEDAL	1
32	12001000/0	ANELLO ELASTICO	SNAP RING	ANNEAU RESSORT	SPRENGRING	1
33	25110267/0	COPRISTAFFA	CLAMP COVER	COUVRE ETRIER	BRIDEDECKEL	1
34	25547039/0	PIASTRINA DESTRA	PLATE RIGHT	PLAQUE DROITE	PLATTE RECHTE	1
35	25547041/0	PIASTRINA SINISTRA	PLATE LEFT	PLAQUE GAUCHE	PLATTE LINKE	1
36	12731601/0	VITE	SCREW	VIS	SCHRAUBE	6

Pos. Nr.	Codice Kodex Code	Descrizione	Description	Description	Beschreibung	Q.tà Q.ty Q.té Menge
37	25033017/1	ASTA	ROD	BARRE	STANGE	1
38	12521350/0	RONDELLA	WASHER	RONDELLE	SCHEIBE	2
39	12155000/0	DADO	NUT	ECROU	MUTTER	1
40	82394500/0	MANOPOLA FRENO	BRAKE KNOB	POIGNEE DE FREIN	BREMSEKNOPF	1
41	25840004/0	ASTA COMANDO FRENO	BRAKE CONTROL ROD	TIGE CONTROLE FREIN	BREMSE KONTROLLESATZ	1
42	12521350/0	RONDELLA	WASHER	RONDELLE	SCHEIBE	2
43	12155000/0	DADO	NUT	ECROU	MUTTER	2
44	82000359/0	LEVE FRENO	BRAKE LEVERS	LEVIERS DE FREIN	BREMSEHEBELN	1
45	25040614/0	BUSSOLA	BUSH	DOUILLE	BÜCHSE	2
46	12608900/0	SEEGER	SEEGER	SEEGER	SEEGER	2
47	25510040/0	PERNO	PIN	PIVOT	BOLZEN	1
48	25670011/0	RONDELLA	WASHER	RONDELLE	SCHEIBE	2
49	12155000/0	DADO	NUT	ECROU	MUTTER	1
50	25033016/0	ASTA	ROD	BARRE	STANGE	1
51	12521350/0	RONDELLA	WASHER	RONDELLE	SCHEIBE	2
52	25430231/0	MOLLA	SPRING	RESSORT	FEDER	1
53	12155000/0	DADO	NUT	ECROU	MUTTER	1
54	25510041/0	PERNO	PIN	PIVOT	BOLZEN	1
55	12155000/0	DADO	NUT	ECROU	MUTTER	1
56	12193200/0	DADO	NUT	ECROU	MUTTER	1
57	12583500/0	GROWER	GROWER	GROWER	GROWER	1
58	12293200/0	DADO	NUT	ECROU	MUTTER	1
59	25430210/0	MOLLA	SPRING	RESSORT	FEDER	1
71	82869009/0	PIANTONE	STEERING COLOMN	TUBE DE DIRECTION	LENKSÄULE	1
72	25040601/0	BUSSOLA	BUSH	DOUILLE	BÜCHSE	2
73	25670006/0	RONDELLA	WASHER	RONDELLE	SCHEIBE	2
74	12001000/0	SEEGER	SEEGER	SEEGER	SEEGER	2

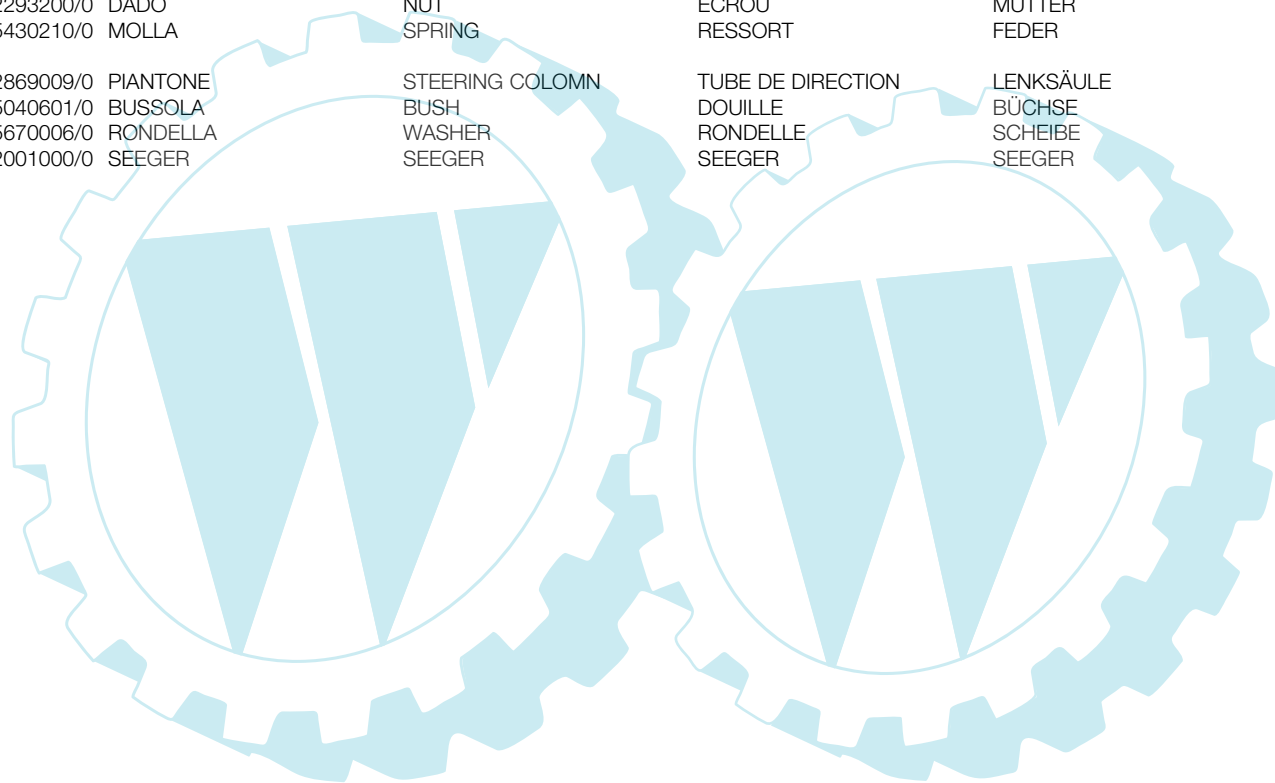

PARTI DI RICAMBIO PER IL TRATTORINO
 SPARE PARTS FOR RIDER-ON-MOWERS
 PIÈCES DETACHÉES POUR TONDEUSE AUTOPORTEE
 RASENTRAKTORERSATZTEILE

TC(P)
TC(P) hydro

Mod. 1998

005

GRUPPO MOTORE 12,5 HP B&S
 ENGINE ASS.Y 12.5 HP B&S
 GROUPE MOTEUR 12,5 HP B&S
 MOTORSATZ 12,5 HP B&S

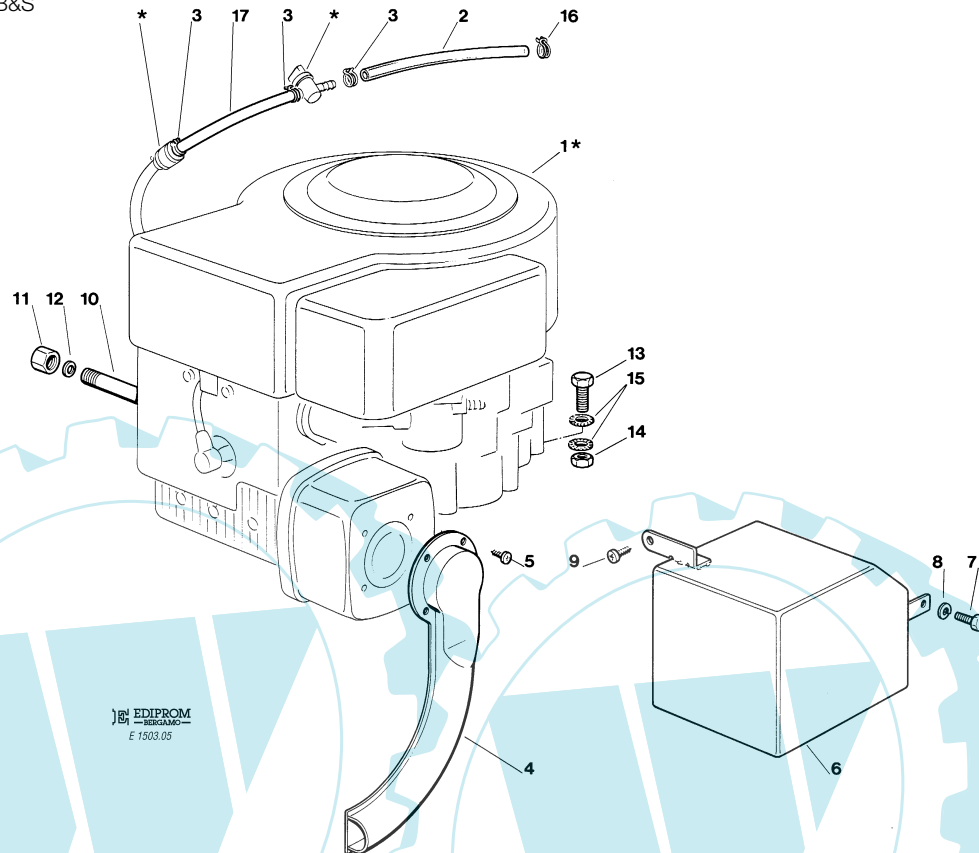

Pos. Nr.	Codice Kodex Code	Descrizione	Description	Description	Beschreibung	Q.tà Q.ty Q.té Menge
1*	—	MOTORE	ENGINE	MOTEUR	MOTOR	1
2	25869016/0	TUBO COLLEGAMENTO	CONNECTING TUBE	TUBE DE CONNEXION	VERBINDUNGSROHR	1
3	18375051/1	FASCETTA	FAIR LED	FIXATION DE CABLE	KABELBEFESTIGUNG	3
4*	82640001/1	RACCORDO SCARICO	EXHAUST CONNECTION	CONNEXION ECHAPPEMENT	AUSPUFFANSCHLUSS	1
5	12735106/0	VITE	SCREW	VIS	SCHRAUBE	4
6	82598001/0	PROTEZIONE SILENZIATORE	MUFFLER PROTECTION	PROTECTION SILENCIEUX	AUSPUFFSCHUTZ	1
7	12735510/0	VITE	SCREW	VIS	SCHRAUBE	1
8	12582100/0	GROWER	GROWER	GROWER	GROWER	1
9	12735104/0	VITE	SCREW	VIS	SCHRAUBE	1
10	25598050/0	PROLUNGA SCARICO OLIO	OIL DISCHARGE EXTENSION	RALLONGE DE DECHAR- MENT HUILE	ÖL ENTLERUNGSVERLAEN- GERUNG	1
11	18737849/0	TAPPO PER PROLUNGA	OIL CAP	BOUCHON HUILE	OELVERSCHLUSS	1
12	18401001/0	GUARNIZIONE	OIL SEAL	GARNITURE	DICHTUNG	1
13	12681100/0	VITE	SCREW	VIS	SCHRAUBE	4
14	12293200/0	DADO	NUT	ECROU	MUTTER	1
	12293201/0	DADO	NUT	ECROU	MUTTER	3
15	12540260/0	RONDELLA	WASHER	RONDELLE	SCHEIBE	2
16	18375052/0	FASCETTA	FAIR LED	FIXATION DE CABLE	KABELBEFESTIGUNG	1
17	25869006/0	TUBO COLLEGAMENTO	CONNECTING TUBE	TUBE DE CONNEXION	VERBINDUNGSROHR	1

PER LA SOSTITUZIONE DELLE PARTI CONTRASSEGNALE CON «*» RIVOLGERSI AL SERVIZIO ASSISTENZA DEL COSTRUTTORE DEL MOTORE.
 TO REPLACE THE PARTS MARKED «*» SEEK ASSISTANCE FROM THE ENGINE MANUFACTURER'S AFTER SALES SERVICE.
 POUR LE REMPLACEMENT DES PIÈCES MARQUÉES AVEC «*» S'ADRESSER AU SERVICE APRÈS VENTES DU CONSTRUCTEUR DU MOTEUR.
 ZUM AUSTAUSCH DER MIT «*» GEKENNZEICHNETEN TEILE, WENDEN SIE SICH AN DEN KUNDENDIENST DES HERSTELLERS DES MOTOR.

PARTI DI RICAMBIO PER IL TRATTORINO
 SPARE PARTS FOR RIDER-ON-MOWERS
 PIECES DETACHEES POUR TONDEUSE AUTOPORTEE
 RASENTRAKTORERSATZTEILE

TC(P)
TC(P) hydro

Mod. 1998

005a

GRUPPO MOTORE 16 - 18 HP B&S
 ENGINE ASS.Y 16 - 18 HP B&S
 GROUPE MOTEUR 16 - 18 HP B&S
 MOTORSATZ 16 - 18 HP B&S

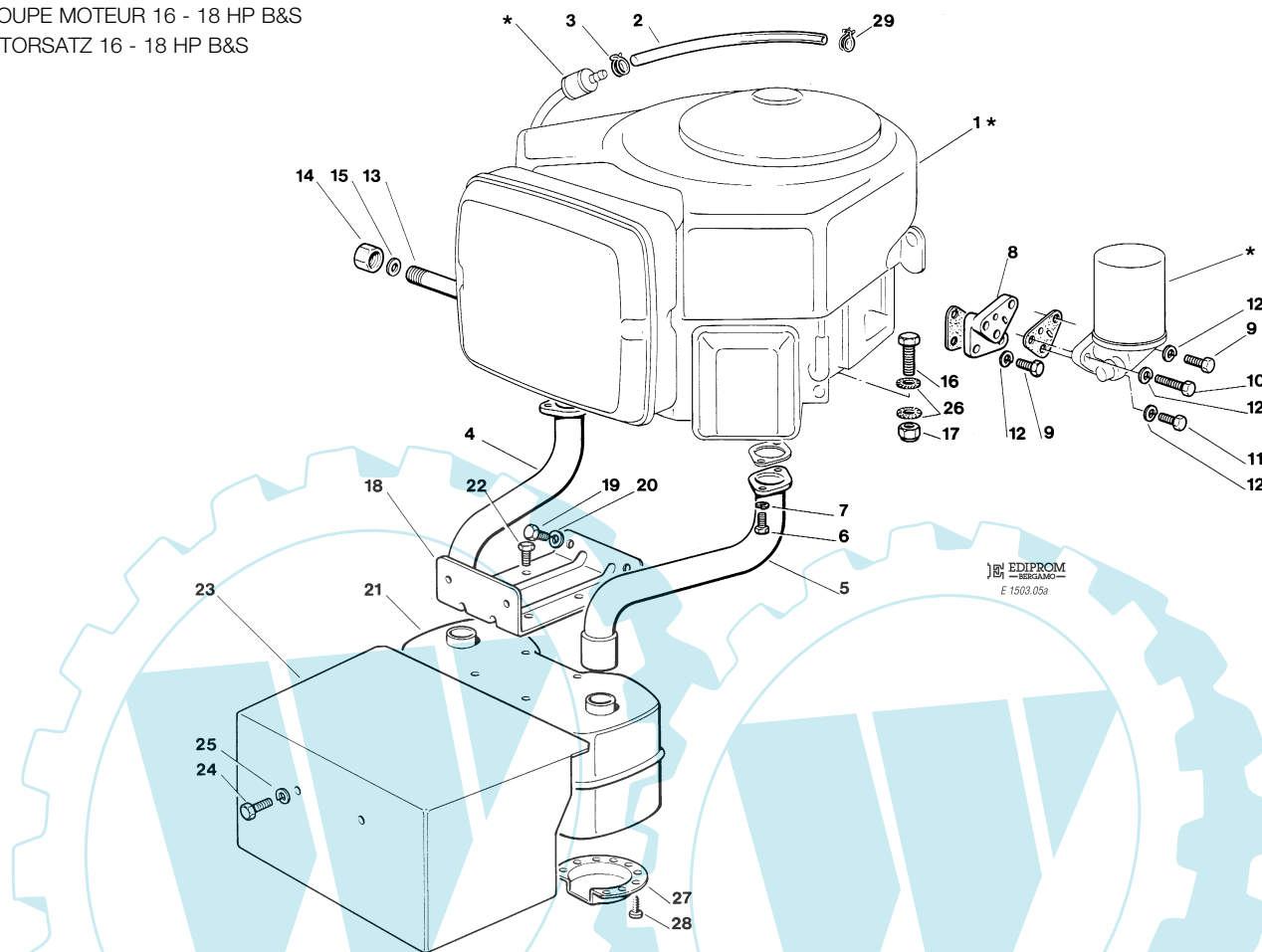

Pos. Nr.	Codice Kodex Code	Descrizione	Description	Description	Beschreibung	Q.tà Q.ty Q.té Menge
1*	—	MOTORE	ENGINE	MOTEUR	MOTOR	1
2	25869017/0	TUBO COLLEGAMENTO	CONNECTING TUBE	TUBE DE CONNEXION	VERBINDUNGSROHR	1
3	18375051/1	FASCETTA	FAIR LED	FIXATION DE CABLE	KABELBEFESTIGUNG	1
4*	18738202/0	TUBO RACCORDO SCARICO DX	EXHAUST RIGHT CONNECTING TUBE	TUBE DE CONNEXION DROIT POUR ECHAPP.	RECHTES VERBINDUNGS- ROHR FÜR ABGASUNG	1
5*	18738203/0	TUBO RACCORDO SCARICO SX	EXHAUST LEFT CONNECTING TUBE	TUBE DE CONNEXION GAUCHE POUR ECHAPP.	LINKES VERBINDUNGS- ROHR FÜR ABGASUNG	1
6	12793101/0	VITE	SCREW	VIS	SCHRAUBE	4
7	12583500/0	GROWER	GROWER	GROWER	GROWER	4
8	25785095/0	SUPPORTO FILTRO	FILTER SUPPORT	SUPPORTE DU FILTRE	WECHSELFILTER HALTER	1
9	12791400/0	VITE	SCREW	VIS	SCHRAUBE	3
10	12689515/0	VITE	SCREW	VIS	SCHRAUBE	1
11	12791213/0	VITE	SCREW	VIS	SCHRAUBE	1
12	12582100/0	GROWER	GROWER	GROWER	GROWER	5
13	25598050/0	PROLUNGA SCARICO OLIO	OIL DISCHARGE EXTENSION	EXTENSION RALLONGE DE DESCHERG. HUILE	ENTLERUNGSVERLAEN- GERUNG	1
14	18737849/0	TAPPO PROLUNGA	OIL CAP	BOUCHON HUILE	OELVERSCHLUSS	1
15	18401001/0	GUARNIZIONE	OIL SEAL	GARNITURE	DICHTUNG	1
16	12793600/0	VITE	SCREW	VIS	SCHRAUBE	4
17	12293201/0	DADO	NUT	ECROU	MUTTER	3
	12293200/0	DADO	NUT	ECROU	MUTTER	1
18	82785093/0	PROTEZIONE SILENZIATORE	MUFFLER PROTECTION	PROTECTION SILENCIEUX	AUSPUFFSCHUTZ	1
19	12793102/0	VITE	SCREW	VIS	SCHRAUBE	2
20	12583500/0	GROWER	GROWER	GROWER	GROWER	2
21*	18716131/1	SILENZIATORE COMPLETO DI DEFLETTORE	MUFFLER WITH DEFLECTOR	SILENCIEUX AVEC DEFLECTEUR	AUSPUFF MIT DEFLEKTOR	1

Pos. Nr.	Codice Kodex Code	Descrizione	Description	Description	Beschreibung	Q.tà Q.ty Q.té Menge
22	12735107/0	VITE	SCREW	VIS	SCHRAUBE	4
23	82598005/1	PROTEZIONE	GUARD	PROTECTION	SCHUTZE	1
24	12792610/0	VITE	SCREW	VIS	SCHRAUBE	2
25	12583500/0	GROWER	GROWER	GROWER	GROWER	2
26	12540260/0	RONDELLA	WASHER	RONDELLE	SCHEIBE	2
27	18310005/0	DEFLETTORE	DEFLECTOR	DEFLECTEUR	DEFLEKTOR	1
28	12735106/0	VITE	SCREW	VIS	SCHRAUBE	4
29	18375052/0	FASCETTA	FAIR LED	FIXATION DE CABLE	KABELBEFESTIGUNG	1

PER LA SOSTITUZIONE DELLE PARTI CONTRASSEGNAE CON «*» RIVOLGERSI AL SERVIZIO ASSISTENZA DEL COSTRUTTORE DEL MOTORE.
 TO REPLACE THE PARTS MARKED «*» SEEK ASSISTANCE FROM THE ENGINE MANUFACTURER'S AFTER SALES SERVICE.
 POUR LE REMPLACEMENT DES PIÈCES MARQUÉES AVEC «*» S'ADRESSER AU SERVICE APRÈS VENTES DU CONSTRUCTEUR DU MOTEUR.
 ZUM AUSTAUSCH DER MIT «*» GEKENNZEICHNETEN TEILE, WENDEN SIE SICH AN DEN KUNDENDIENST DES HERSTELLERS DES MOTOR.

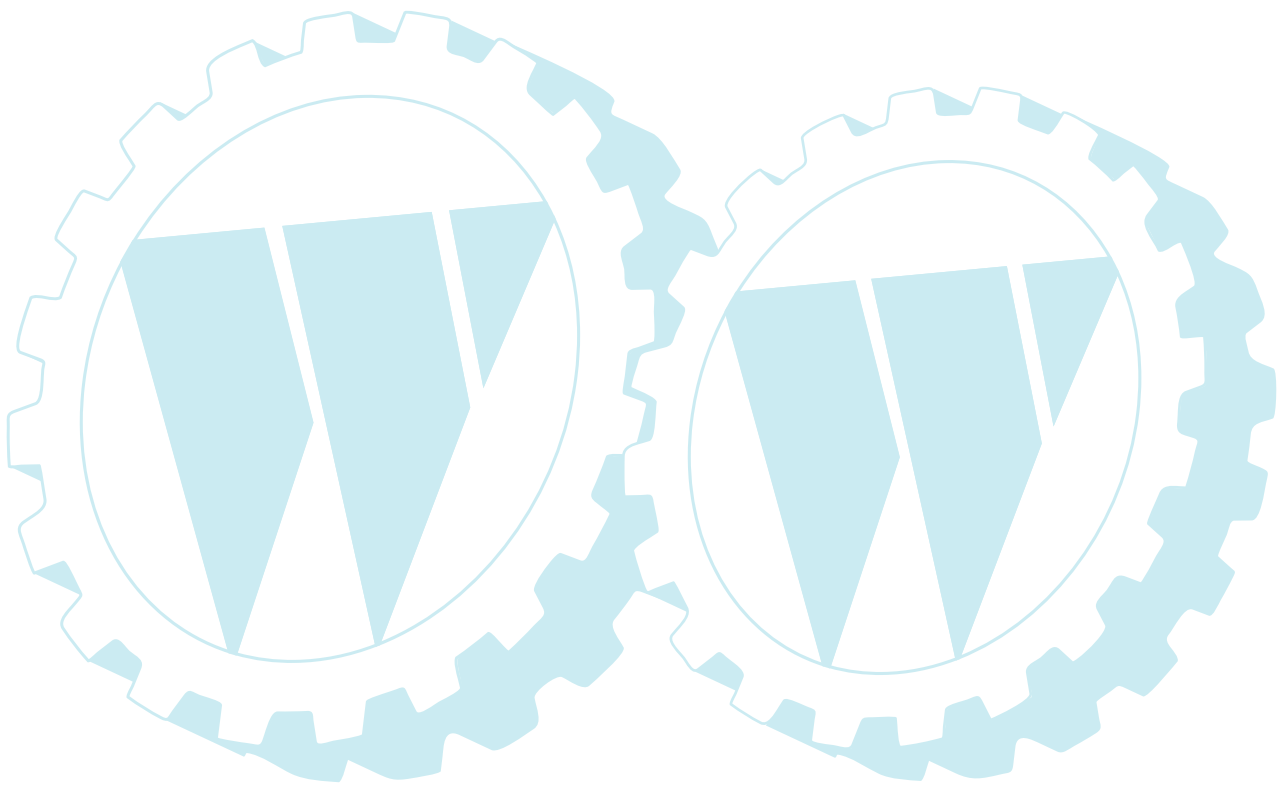

PARTI DI RICAMBIO PER IL TRATTORINO
 SPARE PARTS FOR RIDER-ON-MOWERS
 PIECES DETACHEES POUR TONDEUSE AUTOPORTEE
 RASENTRAKTORERSATZTEILE

TC(P)
TC(P) hydro

Mod. 1998

005b

GRUPPO MOTORE 15,5 HP B&S
 ENGINE ASS.Y 15,5 HP B&S
 GROUPE MOTEUR 15,5 HP B&S
 MOTORSATZ 15,5 HP B&S

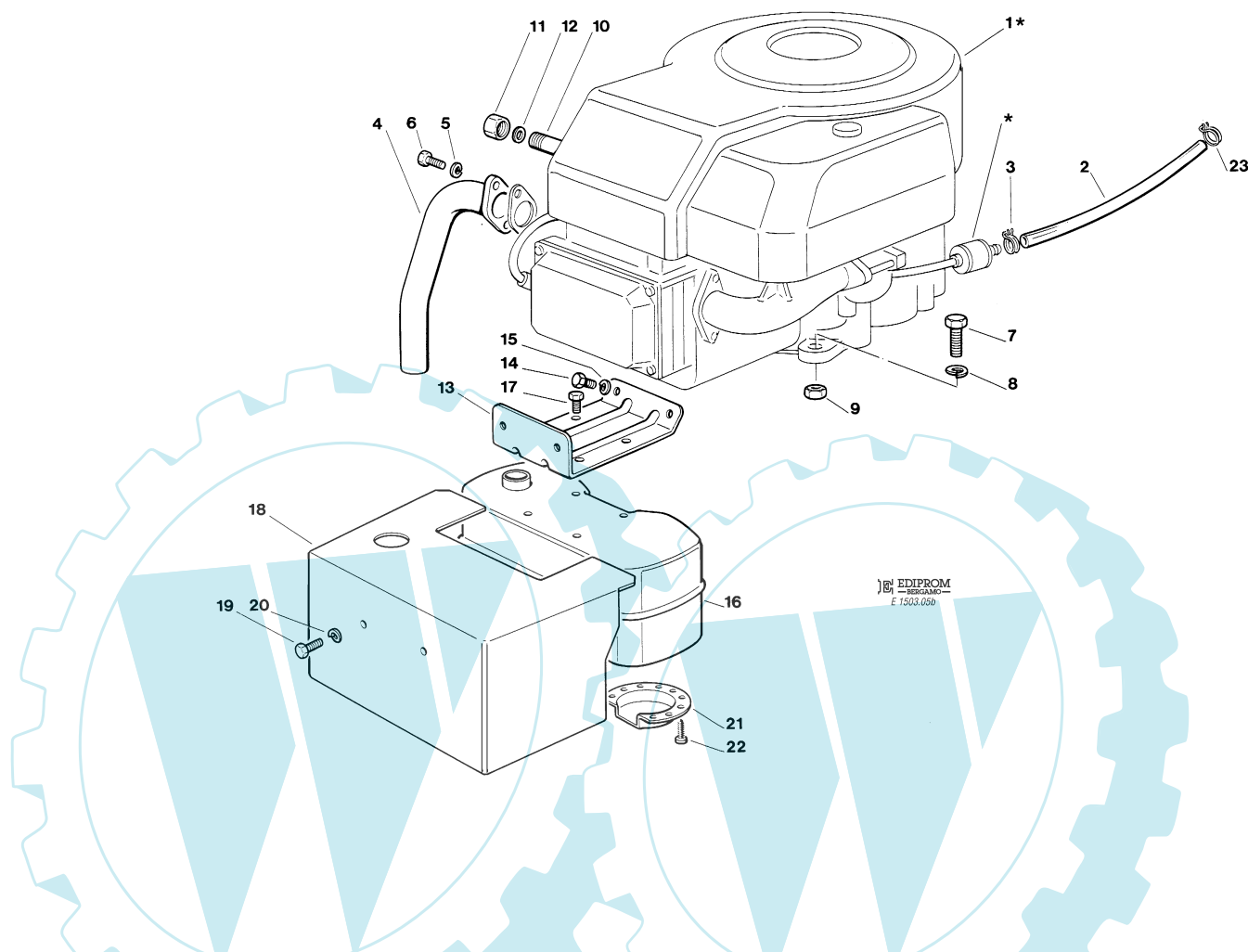

Pos. Nr.	Codice Kodex Code	Descrizione	Description	Description	Beschreibung	Q.tà Q.ty Q.té Menge
1*	—	MOTORE	ENGINE	MOTEUR	MOTOR	1
2	25869016/0	TUBO COLLEGAMENTO	CONNECTING TUBE	TUBE DE CONNEXION	VERBINDUNGSROHR	1
3	18375051/1	FASCETTA	FAIR LED	FIXATION DE CABLE	KABELBEFESTIGUNG	1
4*	18738206/0	TUBO RACCORDO SCARICO	EXHAUST CONNECTING TUBE	TUBE DE CONNEXION POUR ECHAPPEMENT	VERBINDUNGSROHR FÜR ABGASUNG	1
5	12583500/0	GROWER	GROWER	GROWER	GROWER	2
6	12735530/0	VITE	SCREW	VIS	SCHRAUBE	2
7	12793600/0	VITE	SCREW	VIS	SCHRAUBE	4
8	12540260/0	GROWER	GROWER	GROWER	GROWER	4
9	12293200/0	DADO	NUT	ECROU	MUTTER	1
10	25598050/0	PROLUNGA SCARICO OLIO	OIL DISCHARGE	EXTENSION RALLONGE DE DESCHERG. HUILE	ENTLERUNGSVERLAEN- GERUNG	1
11	18737849/0	TAPPO PROLUNGA	OIL CAP	BOUCHON HUILE	OELVERSCHLUSS	1
12	18401001/0	GUARNIZIONE	OIL SEAL	GARNITURE	DICHTUNG	1
13	82785093/0	PROTEZIONE SILENZIATORE	MUFFLER PROTECTION	PROTECTION SILENCIEUX	AUSPUFFSCHUTZ	1
14	12793102/0	VITE	SCREW	VIS	SCHRAUBE	2
15	12583500/0	GROWER	GROWER	GROWER	GROWER	2
16	18716132/0	SILENZIATORE COMPLETO DI DEFLETTORE	MUFFLER WITH DEFLECTOR	SILENCEUX AVEC DEFLECTEUR	AUSPUFF MIT DEFLEKTOR	1
17	12735107/0	VITE	SCREW	VIS	SCHRAUBE	4
18	82598009/1	PROTEZIONE	GUARD	PROTECTION	SCHUTZE	1
19	12792611/0	VITE	SCREW	VIS	SCHRAUBE	2
20	12583500/0	GROWER	GROWER	GROWER	GROWER	2

Pos. Nr.	Codice Kodex Code	Descrizione	Description	Description	Beschreibung	Q.tà Q.ty Q.té Menge
21	18310005/0	DEFLETTORE	DEFLECTOR	DEFLECTEUR	DEFLEKTOR	1
22	12735106/0	VITE	SCREW	VIS	SCHRAUBE	4
23	18375052/0	FASCETTA	FAIR LED	FIXATION DE CABLE	KABELBEFESTIGUNG	1

PER LA SOSTITUZIONE DELLE PARTI CONTRASSEGNAE CON «*» RIVOLGERSI AL SERVIZIO ASSISTENZA DEL COSTRUTTORE DEL MOTORE.
TO REPLACE THE PARTS MARKED «*» SEEK ASSISTANCE FROM THE ENGINE MANUFACTURER'S AFTER SALES SERVICE.
POUR LE REMPLACEMENT DES PIÈCES MARQUÉES AVEC «*» S'ADRESSER AU SERVICE APRÈS VENTES DU CONSTRUCTEUR DU MOTEUR.
ZUM AUSTAUSCH DER MIT «*» GEKENNZEICHNETEN TEILE, WENDEN SIE SICH AN DEN KUNDENDIENST DES HERSTELLERS DES MOTOR.

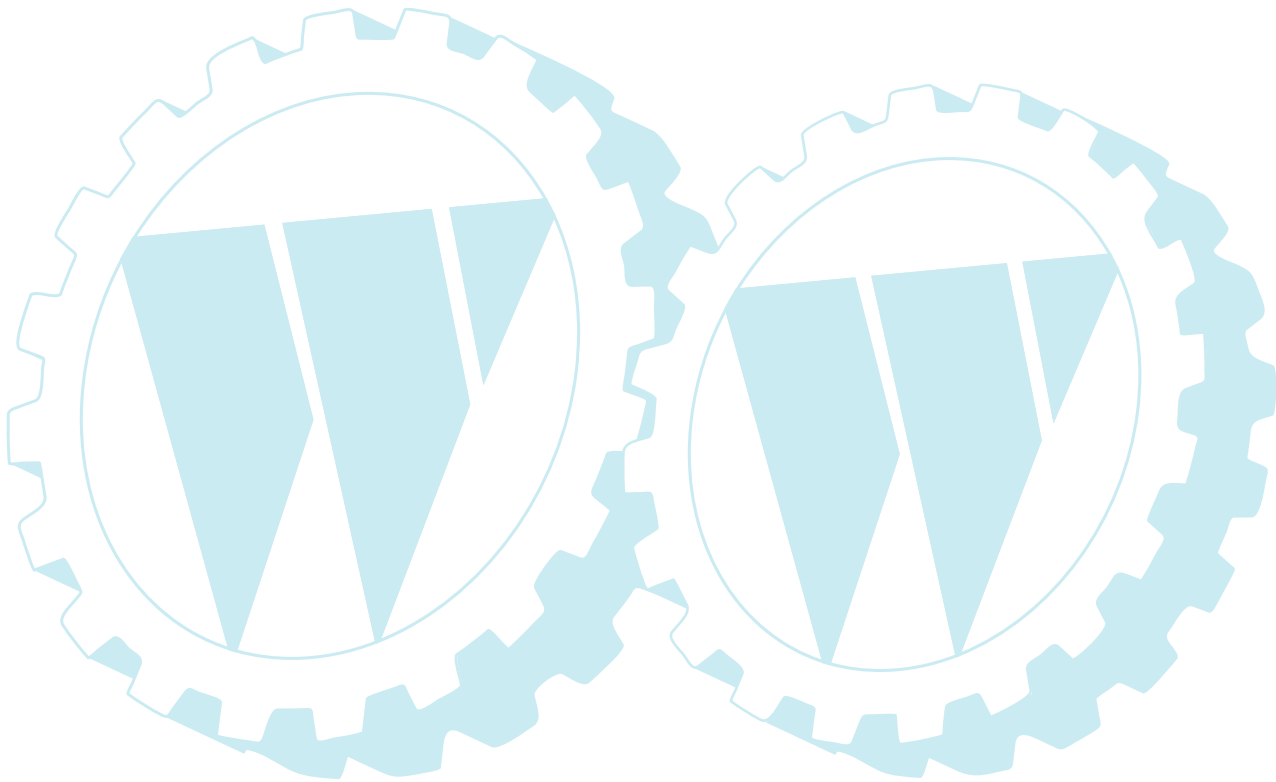

PARTI DI RICAMBIO PER IL TRATTORINO
 SPARE PARTS FOR RIDER-ON-MOWERS
 PIECES DETACHEES POUR TONDEUSE AUTOPORTEE
 RASENTRAKTORERSATZTEILE

TC(P)
TC(P) hydro

Mod. 1998

005c

GRUPPO MOTORE 20 HP B&S
 ENGINE ASS.Y 20 HP B&S
 GROUPE MOTEUR 20 HP B&S
 MOTORSATZ 20 B&S

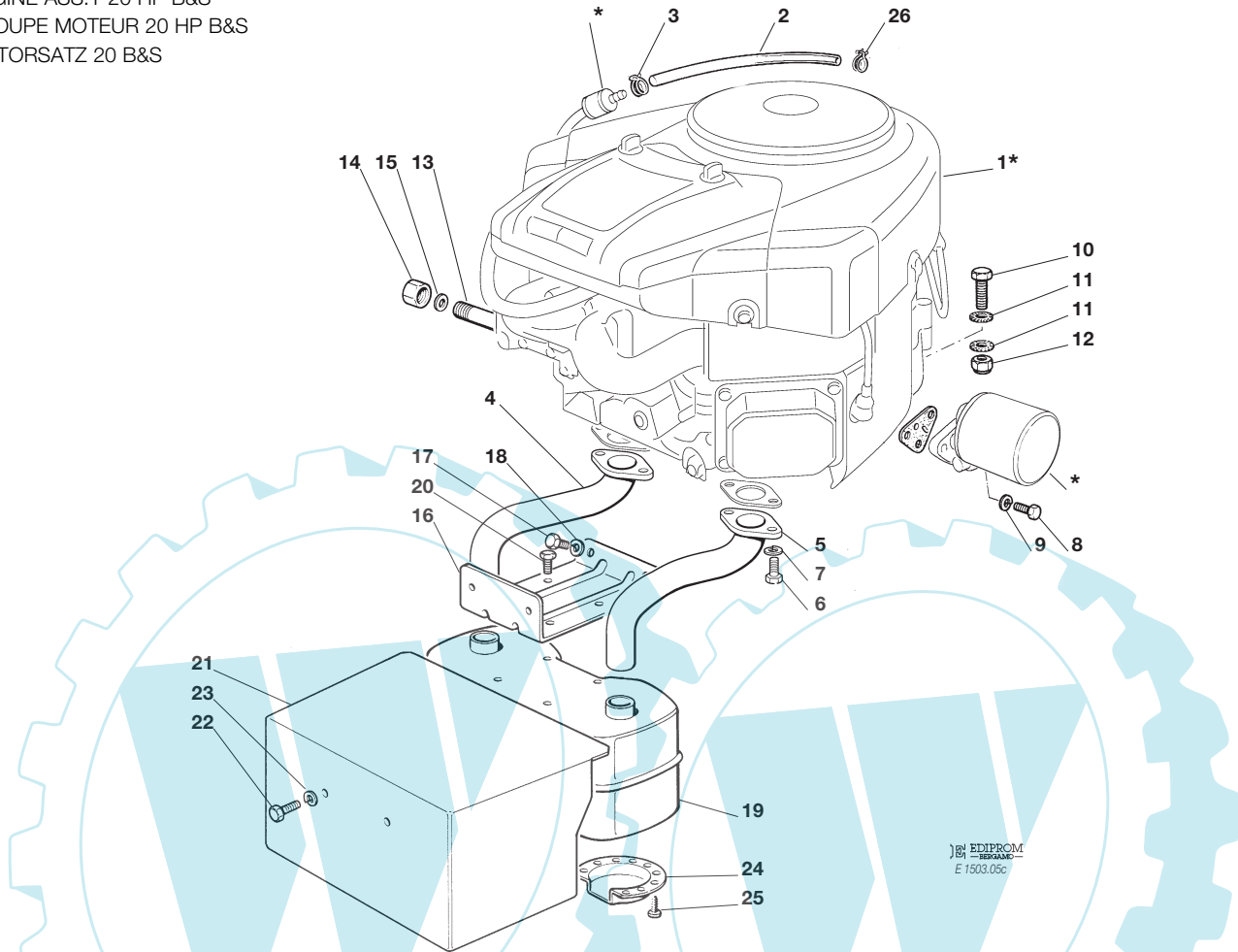

Pos. Nr.	Codice Kodex Code	Descrizione	Description	Description	Beschreibung	Q.tà Q.ty Q.té Menge
1*	—	MOTORE	ENGINE	MOTEUR	MOTOR	1
2	25869016/0	TUBO COLLEGAMENTO	CONNECTING TUBE	TUBE DE CONNEXION	VERBINDUNGSROHR	1
3	18375051/1	FASCETTA	FAIR LED	FIXATION DE CABLE	KABELBEFESTIGUNG	1
4*	18738214/0	TUBO RACCORDO SCARICO DX	EXHAUST RIGHT CONNECTING TUBE	TUBE DE CONNEXION DROIT POUR ECHAPP.	RECHTES VERBINDUNGS- ROHR FÜR ABGASUNG	1
5*	18738215/0	TUBO RACCORDO SCARICO SX	EXHAUST LEFT CONNECTING TUBE	TUBE DE CONNEXION GAUCHE POUR ECHAPP.	LINKES VERBINDUNGS- ROHR FÜR ABGASUNG	1
6	12735530/0	VITE	SCREW	VIS	SCHRAUBE	4
7	12583500/0	GROWER	GROWER	GROWER	GROWER	4
8	12791400/0	VITE	SCREW	VIS	SCHRAUBE	3
9	12582100/0	GROWER	GROWER	GROWER	GROWER	3
10	12691100/0	VITE	SCREW	VIS	SCHRAUBE	4
11	12540260/0	RONDELLA	WASHER	RONDELLE	SCHEIBE	2
12	12293201/0	DADO	NUT	ECROU	MUTTER	3
	12293200/0	DADO	NUT	ECROU	MUTTER	1
13	25598050/0	PROLUNGA SCARICO OLIO	OIL DISCHARGE EXTENSION	EXTENSION RALLONGE DE DESCHERG. HUILE	ENTLERUNGSVERLAEN- GERUNG	1
14	18737849/0	TAPPO PROLUNGA	OIL CAP	BOUCHON HUILE	OELVERSCHLUSS	1
15	18401001/0	GUARNIZIONE	OIL SEAL	GARNITURE	DICHTUNG	1
16	82785093/0	PROTEZIONE SILENZIATORE	MUFFLER PROTECTION	PROTECTION SILENCIEUX	AUSPUFFSCHUTZ	1
17	12793102/0	VITE	SCREW	VIS	SCHRAUBE	2
18	12583500/0	GROWER	GROWER	GROWER	GROWER	2
19*	18716131/1	SILENZIATORE COMPLETO DI DEFLETTORE	MUFFLER WITH DEFLECTOR	SILENCEUX AVEC DEFLECTEUR	AUSPUFF MIT DEFLEKTOR	1
20	12735107/0	VITE	SCREW	VIS	SCHRAUBE	4
21	82598005/1	PROTEZIONE	GUARD	PROTECTION	SCHUTZE	1

Pos. Nr.	Codice Kodex Code	Descrizione	Description	Description	Beschreibung	Q.tà Q.ty Q.té Menge
22	12792610/0	VITE	SCREW	VIS	SCHRAUBE	2
23	12583500/0	GROWER	GROWER	GROWER	GROWER	2
24	18310005/0	DEFLETTORE	DEFLECTOR	DEFLECTEUR	DEFLEKTOR	1
25	12735106/0	VITE	SCREW	VIS	SCHRAUBE	4
26	18375052/0	FASCETTA	FAIR LED	FIXATION DE CABLE	KABELBEFESTIGUNG	1

PER LA SOSTITUZIONE DELLE PARTI CONTRASSEGNAE CON «*» RIVOLGERSI AL SERVIZIO ASSISTENZA DEL COSTRUTTORE DEL MOTORE.
 TO REPLACE THE PARTS MARKED «*» SEEK ASSISTANCE FROM THE ENGINE MANUFACTURER'S AFTER SALES SERVICE.
 POUR LE REMPLACEMENT DES PIÈCES MARQUÉES AVEC «*» S'ADRESSER AU SERVICE APRÈS VENTES DU CONSTRUCTEUR DU MOTEUR.
 ZUM AUSTAUSCH DER MIT «*» GEKENNZEICHNETEN TEILE, WENDEN SIE SICH AN DEN KUNDENDIENST DES HERSTELLERS DES MOTOR.

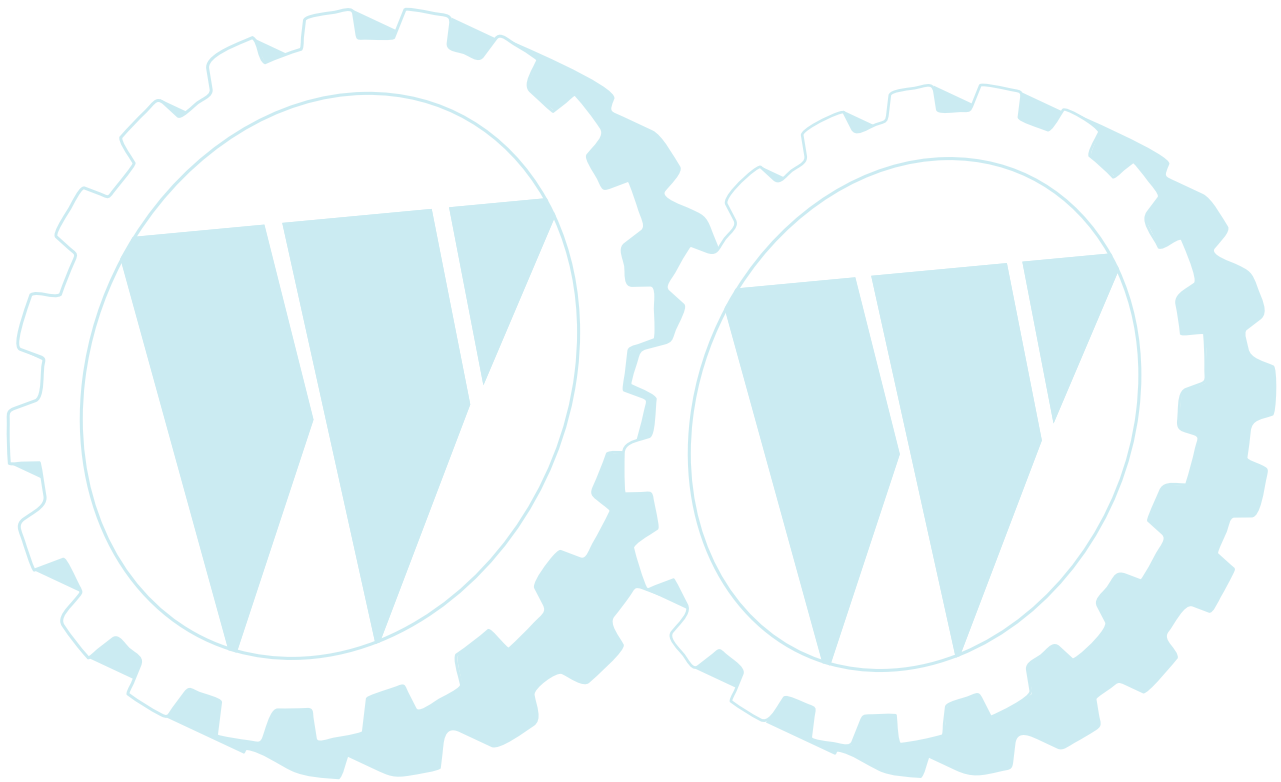

PARTI DI RICAMBIO PER IL TRATTORINO
 SPARE PARTS FOR RIDER-ON-MOWERS
 PIECES DETACHEES POUR TONDEUSE AUTOPORTEE
 RASENTRAKTORERSATZTEILE

TC(P)
TC(P) hydro

Mod. 1998

005d

GRUPPO MOTORE 13 HP TECUMSEH
 ENGINE ASS.Y 13 HP TECUMSEH
 GROUPE MOTEUR 13 HP TECUMSEH
 MOTORSATZ 13 HP TECUMSEH

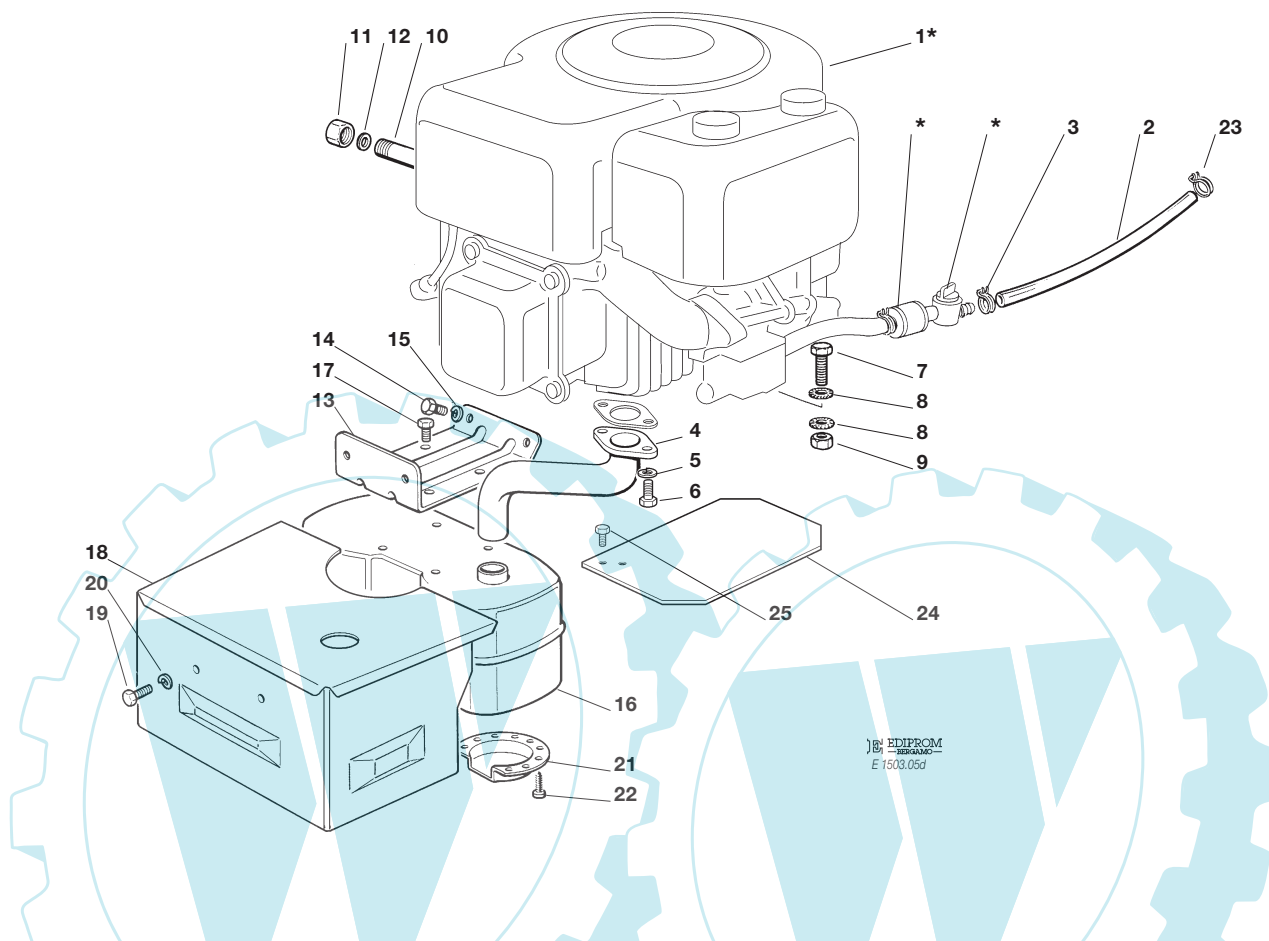

Pos. Nr.	Codice Kodex Code	Descrizione	Description	Description	Beschreibung	Q.tà Q.ty Q.té Menge
1*	—	MOTORE	ENGINE	MOTEUR	MOTOR	1
2	25869027/0	TUBO COLLEGAMENTO	CONNECTING TUBE	TUBE DE CONNEXION	VERBINDUNGSROHR	1
3	18375051/1	FASCETTA	FAIR LED	FIXATION DE CABLE	KABELBEFESTIGUNG	1
4*	18738211/0	TUBO RACCORDO SCARICO	EXHAUST CONNECTING TUBE	TUBE DE CONNEXION POUR ECHAPPEMENT	VERBINDUNGSROHR FÜR ABGASUNG	1
5	12583500/0	GROWER	GROWER	GROWER	GROWER	2
6	12735530/0	VITE	SCREW	VIS	SCHRAUBE	2
7	12691100/0	VITE	SCREW	VIS	SCHRAUBE	4
8	12540260/0	RONDELLA	WASHER	RONDELLE	SCHEIBE	4
9	12293200/0	DADO	NUT	ECROU	MUTTER	1
10	25598050/0	PROLUNGA SCARICO OLIO	OIL DISCHARGE	EXTENSION RALLONGE DE DESCHERG. HUILE	ENTLERUNGSVERLAENGERUNG	1
11	18737849/0	TAPPO PROLUNGA	OIL CAP	BOUCHON HUILE	OELVERSCHLUSS	1
12	18401001/0	GUARNIZIONE	OIL SEAL	GARNITURE	DICHTUNG	1
13	82785093/0	SUPPORTO SILENZIATORE	MUFFLER SUPPORT	SUPPORT SILENCIEUX	AUSPUFFHALTERSATZ	1
14	12793102/0	VITE	SCREW	VIS	SCHRAUBE	2
15	12583500/0	GROWER	GROWER	GROWER	GROWER	2
16	18716132/0	SILENZIATORE COMPLETO DI DEFLETTORE	MUFFLER WITH DEFLECTOR	SILENCEUX AVEC DEFLECTEUR	AUSPUFF MIT DEFLEKTOR	1
17	12735107/0	VITE	SCREW	VIS	SCHRAUBE	4
18	82598017/0	PROTEZIONE	GUARD	PROTECTION	SCHUTZE	1
19	12792611/0	VITE	SCREW	VIS	SCHRAUBE	2
20	12583500/0	GROWER	GROWER	GROWER	GROWER	2
21	18310005/0	DEFLETTORE	DEFLECTOR	DEFLECTEUR	DEFLEKTOR	1
22	12735106/0	VITE	SCREW	VIS	SCHRAUBE	4
23	18375052/0	FASCETTA	FAIR LED	FIXATION DE CABLE	KABELBEFESTIGUNG	1

Pos. Nr.	Codice Kodex Code	Descrizione	Description	Description	Beschreibung	Q.tà Q.ty Q.té Menge
24	25600031/0	PROTEZIONE SILENZIATORE	MUFFLER PROTECTION	PROTECTION SILENCIEUX	AUSPUFFSCHUTZ	1
25	12735106/0	VITE	SCREW	VIS	SCHRAUBE	2

PER LA SOSTITUZIONE DELLE PARTI CONTRASSEGNALE CON «*» RIVOLGERSI AL SERVIZIO ASSISTENZA DEL COSTRUTTORE DEL MOTORE.
TO REPLACE THE PARTS MARKED «*» SEEK ASSISTANCE FROM THE ENGINE MANUFACTURER'S AFTER SALES SERVICE.
POUR LE REMPLACEMENT DES PIÈCES MARQUÉES AVEC «*» S'ADRESSER AU SERVICE APRÈS VENTES DU CONSTRUCTEUR DU MOTEUR.
ZUM AUSTAUSCH DER MIT «*» GEKENNZEICHNETEN TEILE, WENDEN SIE SICH AN DEN KUNDENDIENST DES HERSTELLERS DES MOTOR.

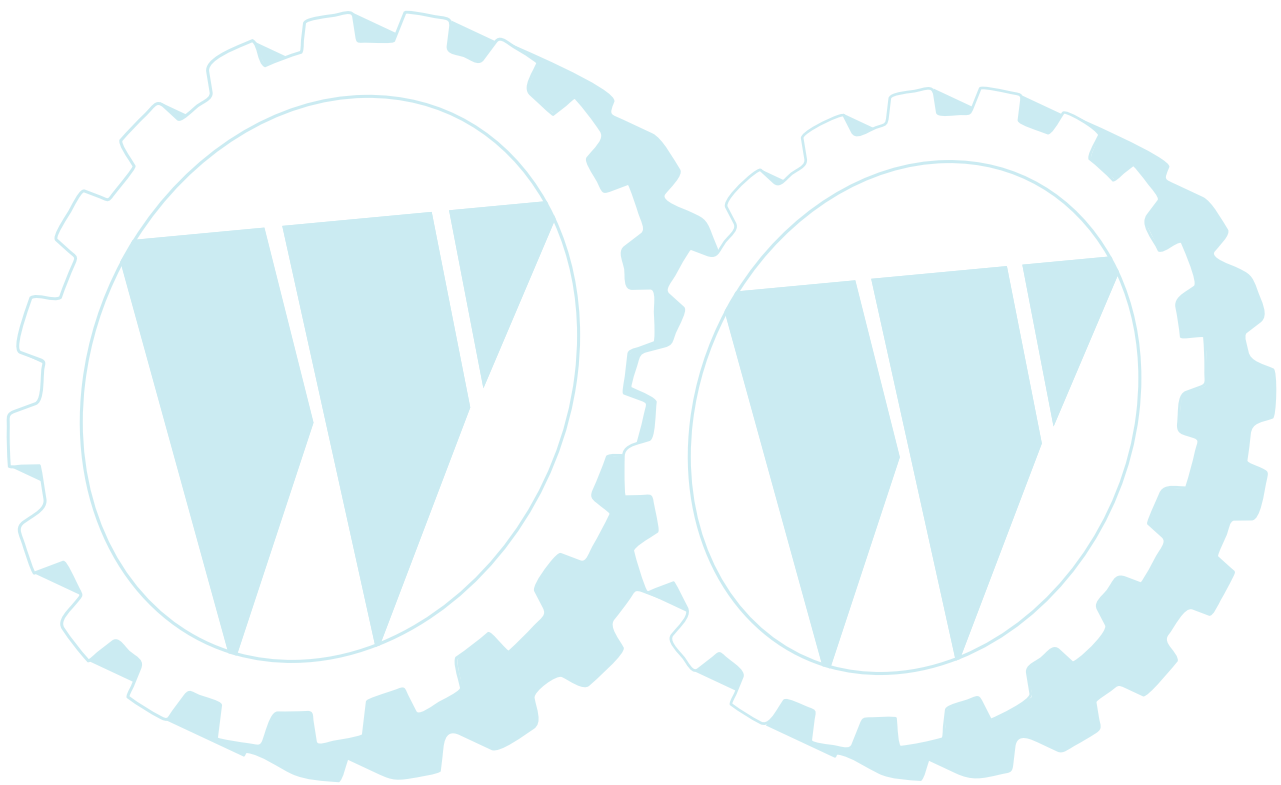

PARTI DI RICAMBIO PER IL TRATTORINO
 SPARE PARTS FOR RIDER-ON-MOWERS
 PIECES DETACHEES POUR TONDEUSE AUTOPORTEE
 RASENTRAKTORERSATZTEILE

TC(P)
TC(P) hydro

Mod. 1998

005e

GRUPPO MOTORE 15 HP TECUMSEH
 ENGINE ASS.Y 15 HP TECUMSEH
 GROUPE MOTEUR 15 HP TECUMSEH
 MOTORSATZ 15 HP TECUMSEH

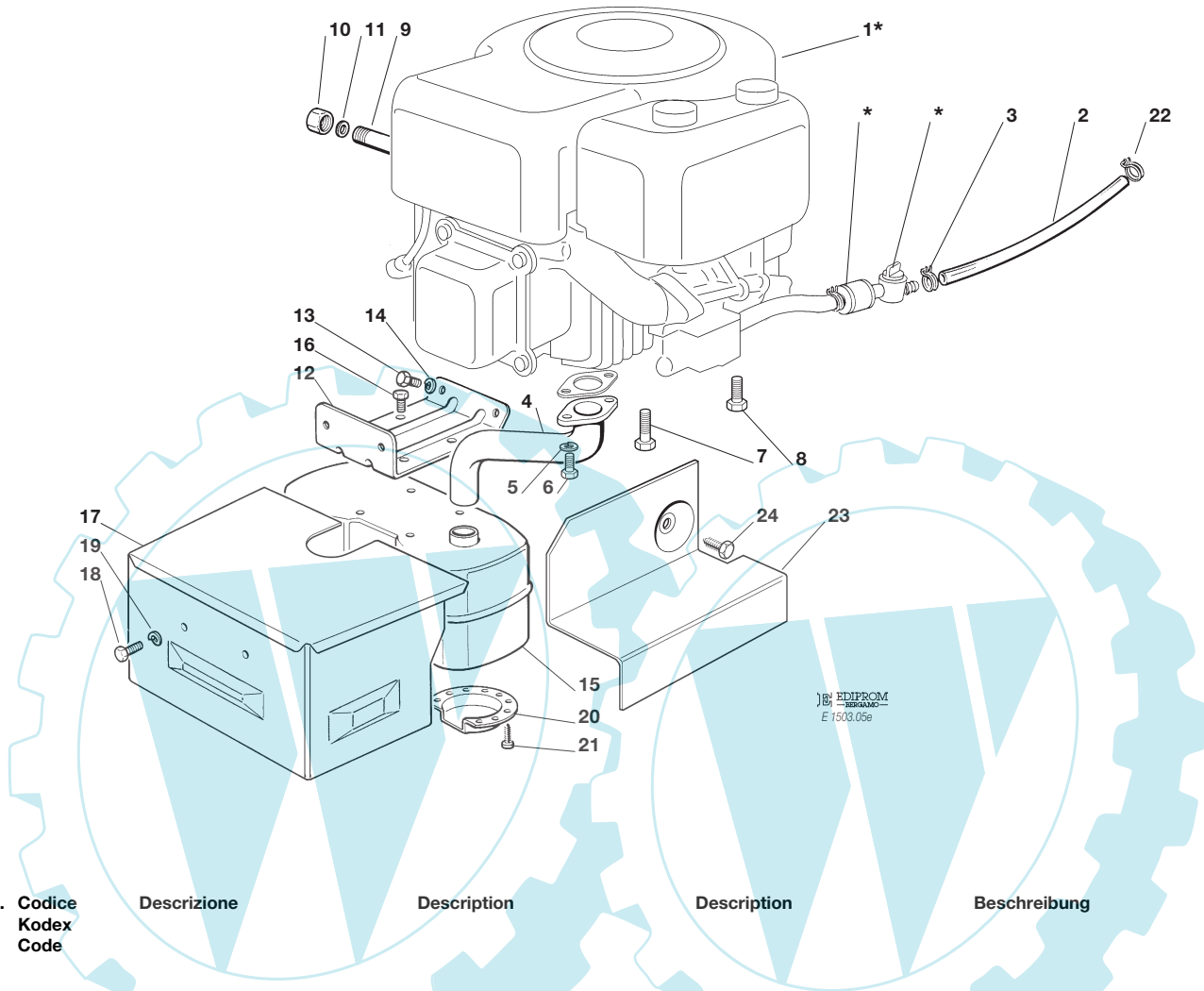

Pos. Nr.	Codice Kodex Code	Descrizione	Description	Description	Beschreibung	Q.tà Q.ty Q.té Menge
1*	—	MOTORE	ENGINE	MOTEUR	MOTOR	1
2	25869027/0	TUBO COLLEGAMENTO	CONNECTING TUBE	TUBE DE CONNEXION	VERBINDUNGSROHR	1
3	18375051/1	FASCETTA	FAIR LED	FIXATION DE CABLE	KABELBEFESTIGUNG	1
4*	18738212/0	TUBO RACCORDO SCARICO	EXHAUST CONNECTING TUBE	TUBE DE CONNEXION POUR ECHAPPEMENT	VERBINDUNGSROHR FÜR ABGASUNG	1
5	12583500/0	GROWER	GROWER	GROWER	GROWER	2
6	12735530/0	VITE	SCREW	VIS	SCHRAUBE	2
7	12735109/0	VITE	SCREW	VIS	SCHRAUBE	3
8	12735108/0	VITE	SCREW	VIS	SCHRAUBE	1
9	25598050/0	PROLUNGA SCARICO OLIO	OIL DISCHARGE	EXTENSION RALLONGE DE DESCHERG. HUILE	ENTLERUNGSVERLAENGERUNG	1
10	18737849/0	TAPPO PROLUNGA	OIL CAP	BOUCHON HUILE	OELVERSCHLUSS	1
11	18401001/0	GUARNIZIONE	OIL SEAL	GARNITURE	DICHTUNG	1
12	82785093/0	SUPPORTO SILENZIATORE	MUFFLER SUPPORT	SUPPORT SILENCIEUX	AUSPUFFHALTERSATZ	1
13	12793102/0	VITE	SCREW	VIS	SCHRAUBE	2
14	12583500/0	GROWER	GROWER	GROWER	GROWER	2
15	18716132/0	SILENZIATORE COMPLETO DI DEFLETTORE	MUFFLER WITH DEFLECTOR	SILENCEUX AVEC DEFLECTEUR	AUSPUFF MIT DEFLEKTOR	1
16	12735107/0	VITE	SCREW	VIS	SCHRAUBE	4
17	82598019/0	PROTEZIONE	GUARD	PROTECTION	SCHUTZE	1
18	12792611/0	VITE	SCREW	VIS	SCHRAUBE	2
19	12583500/0	GROWER	GROWER	GROWER	GROWER	2
20	18310005/0	DEFLETTORE	DEFLECTOR	DEFLECTEUR	DEFLEKTOR	1
21	12735106/0	VITE	SCREW	VIS	SCHRAUBE	4
22	18375052/0	FASCETTA	FAIR LED	FIXATION DE CABLE	KABELBEFESTIGUNG	1

Pos. Nr.	Codice Kodex Code	Descrizione	Description	Description	Beschreibung	Q.tà Q.ty Q.té Menge
23	25600038/0	PROTEZIONE SILENZIATORE	MUFFLER PROTECTION	PROTECTION SILENCIEUX	AUSPUFFSCHUTZ	1
24	12734995/0	VITE	SCREW	VIS	SCHRAUBE	1

PER LA SOSTITUZIONE DELLE PARTI CONTRASSEGNAE CON «*» RIVOLGERSI AL SERVIZIO ASSISTENZA DEL COSTRUTTORE DEL MOTORE.
TO REPLACE THE PARTS MARKED «*» SEEK ASSISTANCE FROM THE ENGINE MANUFACTURER'S AFTER SALES SERVICE.
POUR LE REMPLACEMENT DES PIÈCES MARQUÉES AVEC «*» S'ADRESSER AU SERVICE APRÈS VENTES DU CONSTRUCTEUR DU MOTEUR.
ZUM AUSTAUSCH DER MIT «*» GEKENNZEICHNETEN TEILE, WENDEN SIE SICH AN DEN KUNDENDIENST DES HERSTELLERS DES MOTOR.

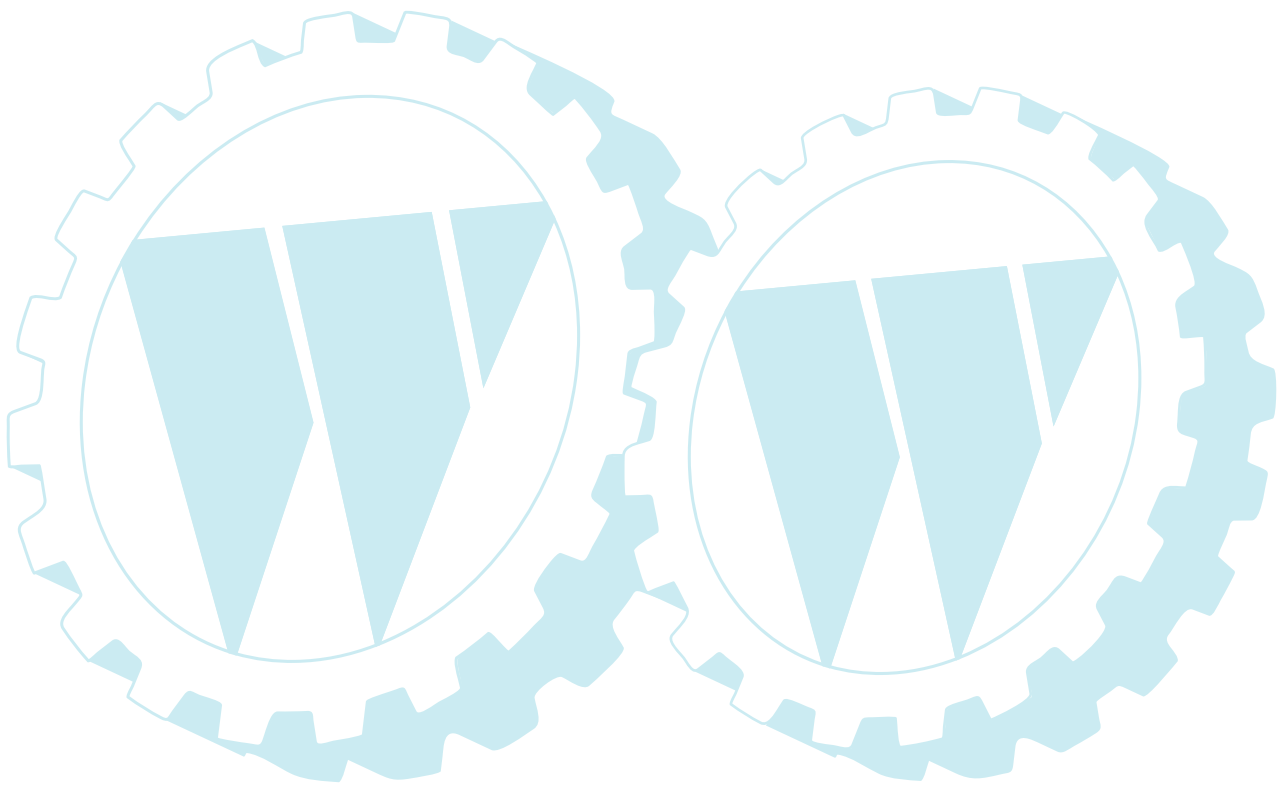

PARTI DI RICAMBIO PER IL TRATTORINO
 SPARE PARTS FOR RIDER-ON-MOWERS
 PIECES DETACHEES POUR TONDEUSE AUTOPORTEE
 RASENTRAKTORERSATZTEILE

TC(P)

GRUPPO TRASMISSIONE
 DRIVE UNIT
 GROUPE TRANSMISSION
 GETRIEBEGRUPPE

Mod. 1998

006

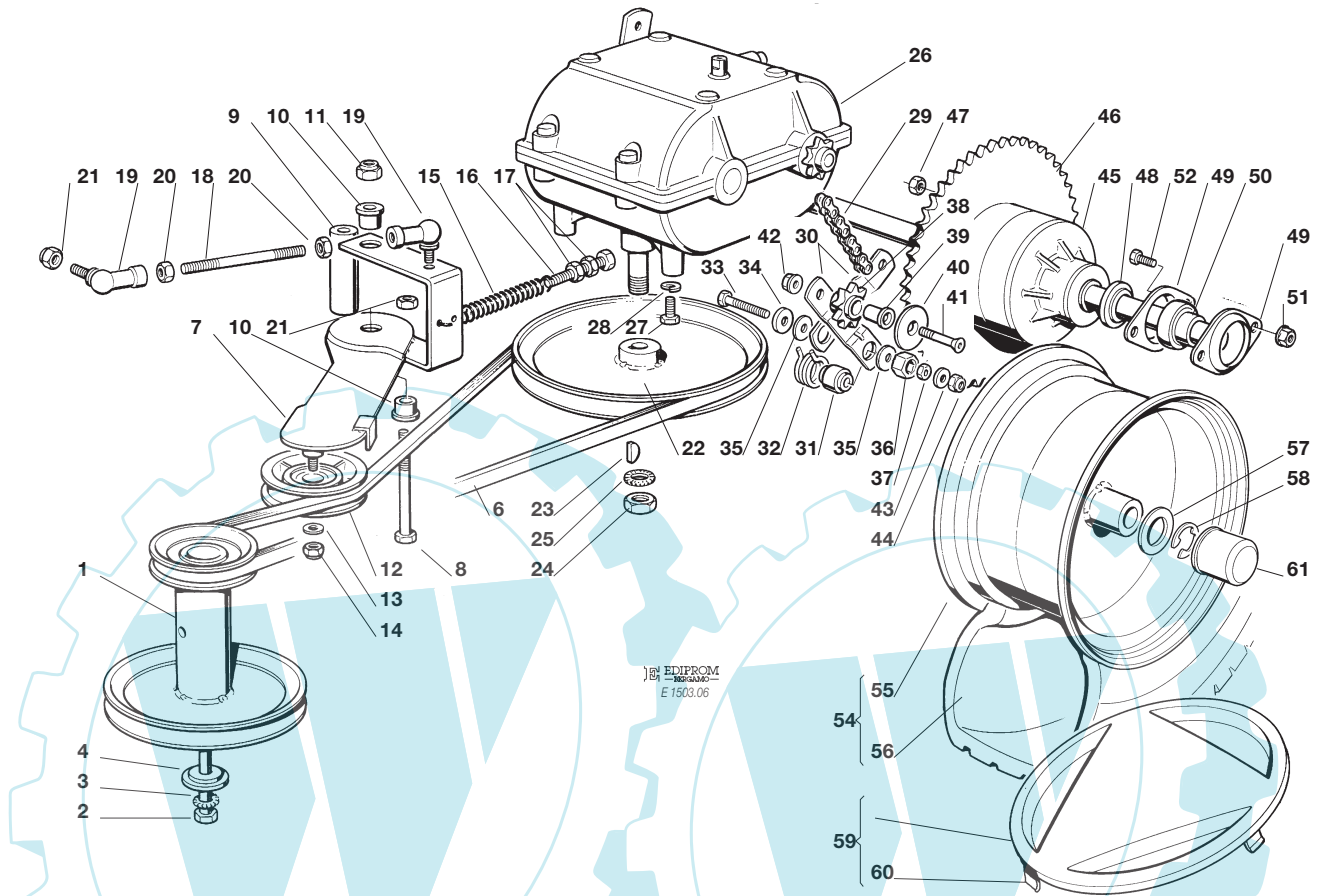

Pos. Nr.	Codice Kodex Code	Descrizione	Description	Description	Beschreibung	Q.tà Q.ty Q.té Menge
1	25601552/1	PULEGGIA MOTORE	ENGINE PULLEY	POULIE MOTEUR	RIEMENSCHLEIBE	1
2	12737310/0	VITE (12,5-15,5-16 HP B&S)	SCREW (12,5-15,5-16 HP B&S)	VIS (12,5-15,5-16 HP B&S)	SCHRAUBE (12,5-15,5-16 HP B&S)	1
3	12543000/0	RONDELLA	WASHER	RONDELLE	SCHEIBE	1
4	22671433/0	BOCCOLA	BUSHING	DOUILLE	BÜCHSE	1
6	35061501/0	CINGHIA	BELT	COURROIE	RIEMEN	1
7	82318111/1	LEVA GALOPPINO	TIGHTENER LEVER	LEVIER GALOPIN	LEIT ROLLE	1
8	12692080/0	VITE	SCREW	VIS	SCHRAUBE	1
9	25160008/0	DISTANZIALE	SPACER	ENTRETOISE	ENTFERNUNGSSTUECK	1
10	25038002/0	BOCCOLA	BUSHING	DOUILLE	BÜCHSE	2
11	12155000/0	DADO	NUT	ECROU	MUTTER	1
12	25601554/0	PULEGGIA	PULLEY	POULIE	RIEMENSCHLEIBE	1
13	12523060/0	RONDELLA	WASHER	RONDELLE	SCHEIBE	1
14	12155000/0	DADO	NUT	ECROU	MUTTER	1
15	25430219/0	MOLLA	SPRING	RESSORT	FEDER	1
16	22943005/0	VITE	SCREW	VIS	SCHRAUBE	1
17	12293200/0	DADO	NUT	ECROU	MUTTER	2
18	25598002/0	PRIGIONIERO	STUD SCREW	PRISONNIER	STIFTSCHLEIBE	1
19	22746601/0	SNODO M8	JOINT M8	JOINT M8	GELENK M8	2
20	12293200/0	DADO	NUT	ECROU	MUTTER	2
21	12155000/0	DADO	NUT	ECROU	MUTTER	2
22	82601501/0	PULEGGIA	PULLEY	POULIE	RIEMENSCHLEIBE	1
23	12138810/0	LINGUETTA	KEY	CLAVETTE	KEIL	1
24	12361010/0	DADO	NUT	ECROU	MUTTER	1
25	12540280/0	RONDELLA	WASHER	RONDELLE	SCHEIBE	1
26*	18159002/0	CAMBIO	GEAR BOX	BOTTE DE VITESSE	GETRIEBE	1

Pos. Nr.	Codice Kodex Code	Descrizione	Description	Description	Beschreibung	Q.tà Q.ty Q.té Menge
27	12735530/0	VITE	SCREW	VIS	SCHRAUBE	4
28	12583500/0	GROWER	GROWER	GROWER	GROWER	4
29	15189001/0	CATENA	CHAIN	CHAINE	KETTE	1
30	25318122/0	LEVA FLOTTANTE	FLOATING LEVER	LEVIER	HEBEL	2
31	25040607/0	BUSSOLA	BUSH	DOUILLE	BUCHSE	1
32	25430207/0	MOLLA	SPRING	RESSORT	FEDER	1
33	25943002/0	VITE	SCREW	VIS	SCHRAUBE	1
34	12523070/0	ROSETTA	WASHER	RONDELLE	SCHEIBE	1
35	22672152/0	RONDELLA ANTIFRIZIONE	WASHER	RONDELLE	SCHEIBE	2
36	25160006/0	DISTANZIALE	SPACER	ENTRETOISE	ENTFERNUNGSSTÜCK	1
37	12293200/0	DADO	NUT	ECROU	MUTTER	1
38	25570001/0	PIGNONE	PINION	PIGNON	RITZEL	2
39	25040608/0	BUSSOLA	BUSH	DOUILLE	BUCHSE	2
40	25670009/0	RONDELLA	WASHER	RONDELLE	SCHEIBE	2
41	12882020/0	VITE	SCREW	VIS	SCHRAUBE	2
42	12155000/0	DADO	NUT	ECROU	MUTTER	2
43	12524010/0	ROSETTA	WASHER	RONDELLE	SCHEIBE	1
44	12155000/0	DADO	NUT	ECROU	MUTTER	1
45*	25140201/0	DIFFERENZIALE	DIFFERENTIAL GEAR	DIFFERENTIEL	DIFFERENTIAL	1
46	16694600/1	CORONA	RING GEAR	COURONNE	KRANZ	1
47	12360354/1	DADO	NUT	ECROU	MUTTER	4
48	25160010/0	DISTANZIALE	SPACER	ENTRETOISE	ENTFERNUNGSSTÜCK	2
49	22207319/0	FLANGIA	FLANGE	BRIDE	FLANSCH	6
50	25122201/0	CUSCINETTO	BEARING	COUSSINET	KUGELLAGER	3
51	12293201/0	DADO	NUT	ECROU	MUTTER	4
52	12793301/0	VITE	SCREW	VIS	SCHRAUBE	2
54	82680003/0	RUOTA COMPLETA (TURF-SAVER)	WHEEL ASS.Y (TURF-SAVER)	ENSEMBLE ROUE (TURF-SAVER)	RAD (TURF-SAVER)	2
55	82000591/1	CERCHIO RUOTA POST.	REAR RIMM	BANDAGE ROUE POST.	HINTERRAD FELGER	2
56	25590001/0	PNEUMATICO (TURF-SAVER)	SHOE (TURF-SAVER)	PNEU (TURF-SAVER)	REIFEN (TURF-SAVER)	2
57	25670005/1	RONDELLA	WASHER	RONDELLE	SCHEIBE	2
58	12001010/0	ANELLO ELASTICO	SNAP RING	ANNEAU RESSORT	SPRENGRING	2
59	82110251/1	COPRIRUOTA POST. (TC)	REAR WHEEL DECK (TC)	COUVRE ROUE POST. (TC)	HINTERRADDECKEL (TC)	2
	82110253/0	COPRIRUOTA POST. (TCP)	REAR WHEEL DECK (TCP)	COUVRE ROUE POST. (TCP)	HINTERRADDECKEL (TCP)	2
60	25430209/0	MOLLA AGGANCIAMENTO	SPRING	RESSORT	FEDER	8
61	22110230/0	COPRIMOZZO	HUB COVER	COUVRE MOYEU	RADNABE DECKEL	2

PER LA SOSTITUZIONE DELLE PARTI CONTRASSEGNALE CON «*», RIVOLGERSI AL SERVIZIO ASSISTENZA DEL COSTRUTTORE (TECUMSEH).
 TO REPLACE THE PARTS MARKED «*» SEEK ASSISTANCE FROM MANUFACTURER'S AFTER SALES SERVICE (TECUMSEH).
 POUR LE REMPLACEMENT DES PIÈCES MARQUÉES AVEC «*», S'ADRESSER AU SERVICE APRÈS VENTES DU CONSTRUCTEUR (TECUMSEH).
 ZUM AUSTAUSCH DER MIT «*» GEKENNZEICHNETEN TEILE, WENDEN SIE SICH AN DEN KUNDENDIENST DES HERSTELLERS (TECUMSEH).

PARTI DI RICAMBIO PER IL TRATTORINO
 SPARE PARTS FOR RIDER-ON-MOWERS
 PIECES DETACHEES POUR TONDEUSE AUTOPORTEE
 RASENTRAKTORERSATZTEILE

TC(P) hydro

GRUPPO TRASMISSIONE
 DRIVE UNIT
 GROUPE TRANSMISSION
 GETRIEBEGRUPPE

Mod. 1998 **006.1**

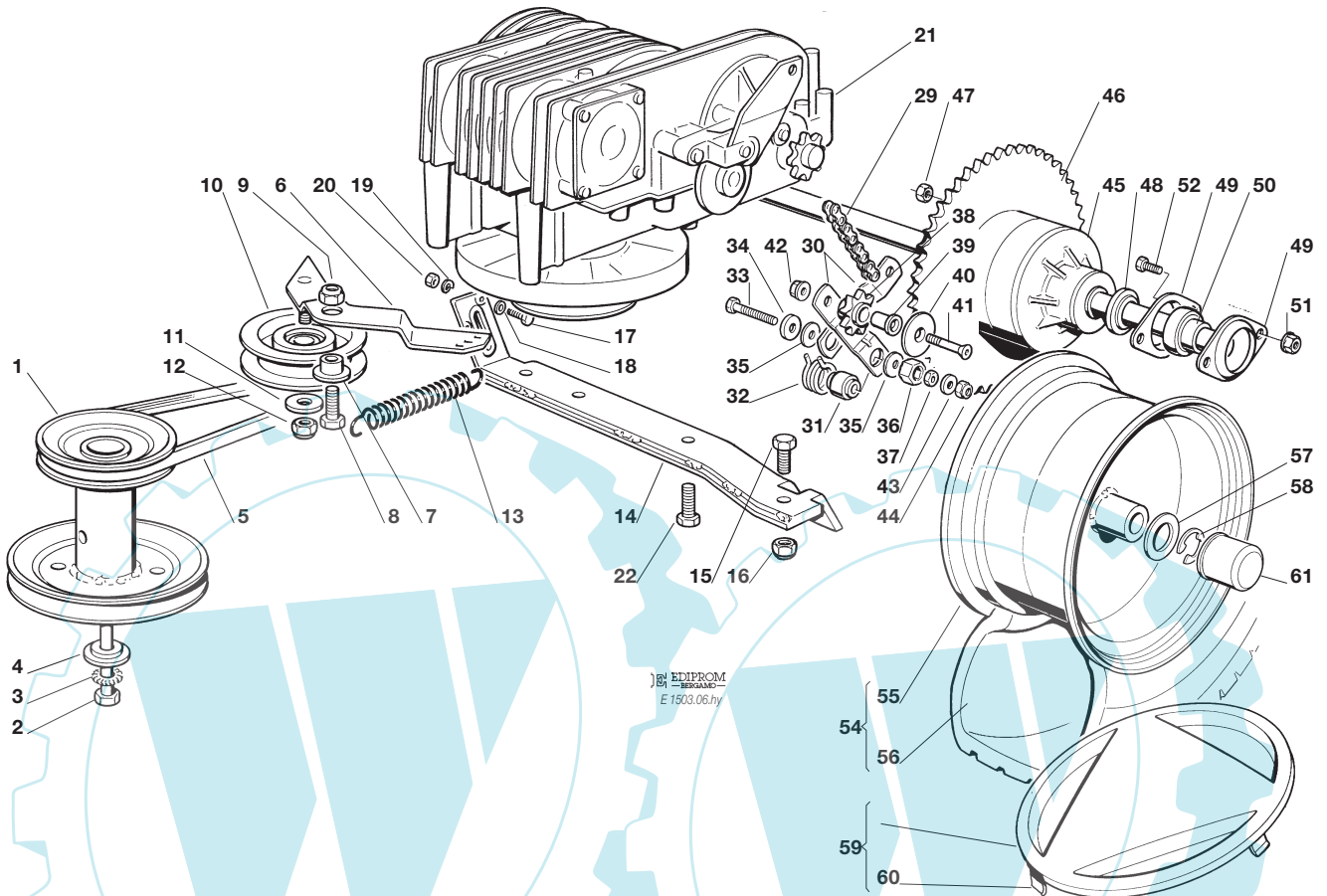

Pos. Nr.	Codice Kodex Code	Descrizione	Description	Description	Beschreibung	Q.tà Q.ty Q.té Menge
1	25601565/0	PULEGGIA MOTORE	ENGINE PULLEY	POULIE MOTEUR	RIEMENSCHLEIBE	1
2	12737310/0	VITE	SCREW	VIS	SCHRAUBE	1
3	12543000/0	RONDELLA	WASHER	RONDELLE	SCHEIBE	1
4	22671433/0	BOCCOLA	BUSHING	DOUILLE	BÜCHSE	1
5	35061426/0	CINGHIA	BELT	COURROIE	RIEMEN	1
6	82318113/0	LEVA GALOPPINO	TIGHTENER LEVER	LEVIER GALOPIN	LEIT ROLLE	1
7	25038002/0	BOCCOLA	BUSHING	DOUILLE	BÜCHSE	1
8	12793102/0	VITE	SCREW	VIS	SCHRAUBE	1
9	12155000/0	DADO	NUT	ECROU	MUTTER	1
10	25601554/0	PULEGGIA	PULLEY	POULIE	RIEMENSCHLEIBE	1
11	12523060/0	RONDELLA	WASHER	RONDELLE	SCHEIBE	1
12	12155000/0	DADO	NUT	ECROU	MUTTER	1
13	25430219/0	MOLLA	SPRING	RESSORT	FEDER	1
14	82785095/0	SUPPORT	BRACKET	SUPPORT	SUPPORT	1
15	12793301/0	VITE	SCREW	VIS	SCHRAUBE	2
16	12155010/0	DADO	NUT	ECROU	MUTTER	2
17	12651010/0	VITE	SCREW	VIS	SCHRAUBE	2
18	12521300/0	RONDELLA	WASHER	RONDELLE	SCHEIBE	2
19	12581100/0	GROWER	GROWER	GROWER	GROWER	2
20	12290791/0	DADO	NUT	ECROU	MUTTER	2
21*	18400900/0	GRUPPO IDROSTATICO	HYDROSTATIC UNIT	ENS. HYDROSTATIQUE	HYDROSTATIK GRUPPE	1
22	12735595/0	VITE	SCREW	VIS	SCHRAUBE	4
29	15189001/0	CATENA	CHAIN	CHAINE	KETTE	1
30	25318122/0	LEVA FLOTTANTE	FLOATING LEVER	LEVIER	HEBEL	2
31	25040607/0	BUSSOLA	BUSH	DOUILLE	BÜCHSE	1
32	25430207/0	MOLLA	SPRING	RESSORT	FEDER	1

Pos. Nr.	Codice Kodex Code	Descrizione	Description	Description	Beschreibung	Q.tà Q.ty Q.té Menge
33	25943002/0	VITE	SCREW	VIS	SCHRAUBE	1
34	12523070/0	ROSETTA	WASHER	RONDELLE	SCHIBE	1
35	22672152/0	RONDELLA ANTIFRIZIONE	WASHER	RONDELLE	SCHIBE	2
36	25160006/0	DISTANZIALE	SPACER	ENTRETOISE	ENTFERNUNGSSTÜCK	1
37	12293200/0	DADO	NUT	ECROU	MUTTER	1
38	25570001/0	PIGNONE	PINION	PIGNON	RITZEL	2
39	25040608/0	BUSSOLA	BUSH	DOUILLE	BUCHSE	2
40	25670009/0	RONDELLA	WASHER	RONDELLE	SCHIBE	2
41	12882020/0	VITE	SCREW	VIS	SCHRAUBE	2
42	12155000/0	DADO	NUT	ECROU	MUTTER	2
43	12524010/0	ROSETTA	WASHER	RONDELLE	SCHIBE	1
44	12155000/0	DADO	NUT	ECROU	MUTTER	1
45*	25140200/2	DIFFERENZIALE	DIFFERENTIAL GEAR	DIFFERENTIEL	DIFFERENTIAL	1
46	16694600/1	CORONA	RING GEAR	COURONNE	KRANZ	1
47	12360354/1	DADO	NUT	ECROU	MUTTER	4
48	25160010/0	DISTANZIALE	SPACER	ENTRETOISE	ENTFERNUNGSSTÜCK	2
49	22207319/0	FLANGIA	FLANGE	BRIDE	FLANSCH	6
50	25122201/0	CUSCINETTO	BEARING	COUSSINET	KUGELLAGER	3
51	12293201/0	DADO	NUT	ECROU	MUTTER	4
52	12793301/0	VITE	SCREW	VIS	SCHRAUBE	2
54	82680003/0	RUOTA COMPLETA (TURF-SAVER)	WHEEL ASS.Y (TURF-SAVER)	ENSEMBLE ROUE (TURF-SAVER)	RAD (TURF-SAVER)	2
55	82000591/1	CERCHIO RUOTA POST.	REAR RIMM	BANDAGE ROUE POST.	HINTERRAD FELGER	2
56	25590001/0	PNEUMATICO (TURF-SAVER)	SHOE (TURF-SAVER)	PNEU (TURF-SAVER)	REIFEN (TURF-SAVER)	2
57	25670005/1	RONDELLA	WASHER	RONDELLE	SCHIBE	2
58	12001010/0	ANELLO ELASTICO	SNAP RING	ANNEAU RESSORT	SPRENGRING	2
59	82110251/1	COPRIRUOTA POST. (TC)	REAR WHEEL DECK (TC)	COUVRE ROUE POST. (TC)	HINTERRADDECKEL (TC)	2
	82110253/0	COPRIRUOTA POST. (TCP)	REAR WHEEL DECK (TCP)	COUVRE ROUE POST. (TCP)	HINTERRADDECKEL (TCP)	2
60	25430209/0	MOLLA AGGANCIO	SPRING	RESSORT	FEDER	8
61	22110230/0	COPRIMOZZO	HUB COVER	COUVRE MOYEU	RADNABE DECKEL	2

PER LA SOSTITUZIONE DELLE PARTI CONTRASSEGNAE CON «*» RIVOLGERSI AL SERVIZIO ASSISTENZA DEL COSTRUTTORE (TECUMSEH).
 TO REPLACE THE PARTS MARKED «*» SEEK ASSISTANCE FROM MANUFACTURER'S AFTER SALES SERVICE (TECUMSEH).
 POUR LE REMPLACEMENT DES PIÈCES MARQUÉES AVEC «*» S'ADRESSER AU SERVICE APRÈS VENTES DU CONSTRUCTEUR (TECUMSEH).
 ZUM AUSTAUSCH DER MIT «*» GEKENNZEICHNETEN TEILE, WENDEN SIE SICH AN DEN KUNDENDIENST DES HERSTELLERS (TECUMSEH).

PARTI DI RICAMBIO PER IL TRATTORINO
 SPARE PARTS FOR RIDER-ON-MOWERS
 PIECES DETACHEES POUR TONDEUSE AUTOPORTEE
 RASENTRAKTORERSATZTEILE

TC(P)
TC(P) hydro

GRUPPO SOLLEVAMENTO PIATTO
 CUTTING PLATE LIFTING ASS.Y
 ENS. SOULEVEMENT PLATEAU DE COUPE
 SCHNEIDWERKZEUG AUFHEBESATZ

Mod. 1998

007

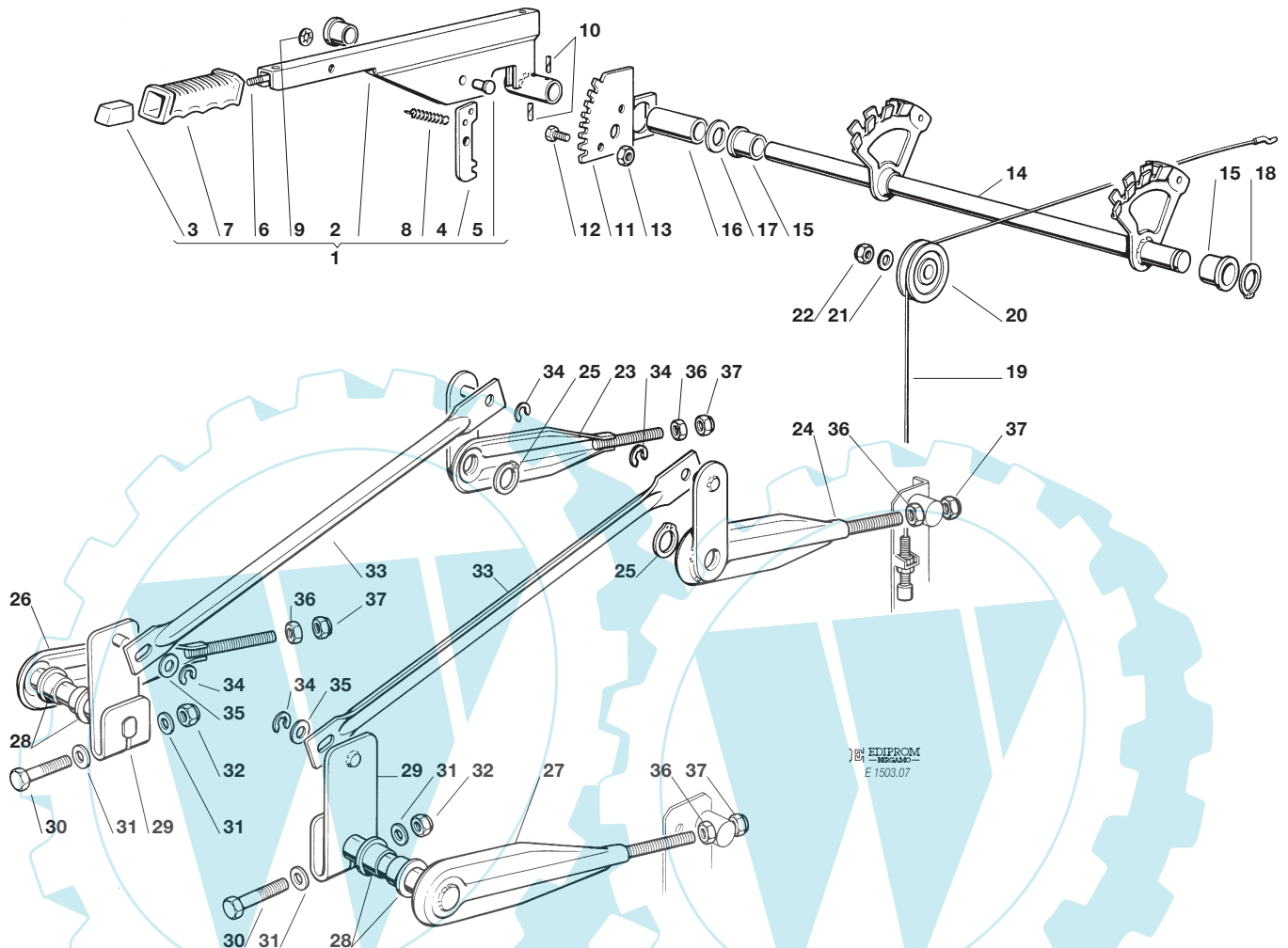

Pos. Nr.	Codice Kodex Code	Descrizione	Description	Description	Beschreibung	Q.tà Q.ty Q.té Menge
1	82300000/0	ASS. GRUPPO LEVA SOLLEVAMENTO PIATTO	LIFTING LEVER ASS.Y	ENS. LEVIER SOULEVEMENT PLATEAU DE COUPE	SCHNEIDWERKZEUG AUFHEBENHEBEL	1
2	82318103/0	LEVA SOLLEVAMENTO	LIFTING LEVER	LEVIER DE SOULEVEMENT	AUFHEBENHEBEL	1
3	82605000/0	PULSANTE	BUTTON	POUSSOIR	DRUCKKNOPF	1
4	25470901/0	NASELLO	DOG	DECLIC	NASE	1
5	25510011/0	PERNO	PIN	PIVOT	BOLZEN	1
6	25033002/0	ASTA COMANDO	PUSHROD	TIGE COMMANDE	BETAETIGUNGSSTAB	1
7	25394504/0	MANOPOLA	KNOB	POIGNEE	GRIFF	1
8	25430208/0	MOLLA	SPRING	RESSORT	FEDER	1
9	12604899/0	RONDELLA	WASHER	RONDELLE	SCHEIBE	1
10	12620206/0	SPINA	PIN	GOUPILLE	STIFT	1
11	25735501/0	SETTORE REGOLAZIONE	ADJ. SECTOR	SECTEUR REGLEMENT	EINSTELLESEKTOR	1
12	12792611/0	VITE	SCREW	VIS	SCHRAUBE	2
13	12293201/0	DADO	NUT	ECROU	MUTTER	2
14	82000401/1	ASS. ASSE SOLLEVAMENTO	LIFTING SHAFT	ARBRE SOULEVEMENT	AUFHEBENACHSE	1
15	22034523/0	BOCCOLA	BUSH	DOUILLE	BÜCHSE	3
16	25160004/0	DISTANZIALE	SPACER	ENTRETOISE	ENTFERNUNGSSTUECK	1
17	12521410/0	RONDELLA	WASHER	RONDELLE	SCHEIBE	1
18	12609260/0	SEGER	SEGER	SEGER	SEGER	1
19	82004600/0	ASS. FILO SOLLEVAMENTO	LIFTING WIRE	ENS. FIL SOULEVEMENT	AUFHEBENKABEL	2
	82004605/0	FILO SOLLEVAMENTO SINISTRO (hydro)	LIFTING WIRE - LEFT (hydro)	ENS. FIL SOULEVEMENT GAUCHE (hydro)	AUFHEBENKABEL LINKE (hydro)	1
20	25601557/0	PULEGGIA	PULLEY	POULIE	SCHEIBE	2

Pos. Nr.	Codice Kodex Code	Descrizione	Description	Description	Beschreibung	Q.tà Q.ty Q.té Menge
21	12521350/0	RONDELLA	WASHER	RONDELLE	SCHEIBE	2
22	12155000/0	DADO	NUT	ECROU	MUTTER	2
23	82318105/1	LEVA FULCRO DX (TC(P) 102)	RIGHT FULCRUM LEVER (TC(P) 102)	LEVIER POINT D'APPUI DROITE (TC(P) 102)	RECHTER SCHWENKPUNKT HEBEL (TC(P) 102)	1
	82318119/1	LEVA FULCRO DX (TC(P) 122)	RIGHT FULCRUM LEVER (TC(P) 122)	LEVIER POINT D'APPUI DROITE (TC(P) 122)	RECHTER SCHWENKPUNKT HEBEL (TC(P) 122)	1
24	82318107/1	LEVA FULCRO SX (TC(P) 102)	LEFT FULCRUM LEVER (TC(P) 102)	LEVIER POINT D'APPUI GAUCHE (TC(P) 102)	LINKER SCHWENKPUNKT HEBEL (TC(P) 102)	1
	82318121/1	LEVA FULCRO SX (TC(P) 122)	LEFT FULCRUM LEVER (TC(P) 122)	LEVIER POINT D'APPUI GAUCHE (TC(P) 122)	LINKER SCHWENKPUNKT HEBEL (TC(P) 122)	1
25	12609255/0	ANELLO	RING	ANNEAU	RING	2
26	82318115/0	LEVA FULCRO ANTERIORE DX (TC(P) 102)	FRONT FULCRUM LEVER RIGHT (TC(P) 102)	LEVIER POINT D'APPUI ANT. DROITE (TC(P) 102)	RECHTER VORDERSCHWENK- PUNKTHEBEL (TC(P) 102)	1
	82318123/0	LEVA FULCRO ANTERIORE DX (TC(P) 122)	FRONT FULCRUM LEVER RIGHT (TC(P) 122)	LEVIER POINT D'APPUI ANT. DROITE (TC(P) 122)	RECHTER VORDERSCHWENK- PUNKTHEBEL (TC(P) 122)	1
27	82318117/0	LEVA FULCRO ANTERIORE SX (TC(P) 102)	FRONT FULCRUM LEVER LEFT (TC(P) 102)	LEVIER POINT D'APPUI ANT. GAUCHE (TC(P) 102)	LINKER VORDERSCHWENK- PUNKTHEBEL (TC(P) 102)	1
	82318125/0	LEVA FULCRO ANTERIORE SX (TC(P) 122)	FRONT FULCRUM LEVER LEFT (TC(P) 122)	LEVIER POINT D'APPUI ANT. GAUCHE (TC(P) 122)	LINKER VORDERSCHWENK- PUNKTHEBEL (TC(P) 122)	1
28	25040605/0	BUSSOLA	BUSH	DOUILLE	BÜCHSE	4
29	82318109/0	LEVA ASTA COLLEGAMENTO	CONNECTING ROD LEVER	LEVIER TIGE DE CONNEXION	VERBINDUGSSTAB HEBEL	2
30	12691700/0	VITE	SCREW	VIS	SCHRAUBE	2
31	12521350/0	RONDELLA	WASHER	RONDELLE	SCHEIBE	4
32	12155000/0	DADO	NUT	ECROU	MUTTER	2
33	25033001/0	ASTA COLLEGAMENTO	CONNECTING ROD	TIGE DE CONNEXION	VERBINDUGSSTAB	2
34	12000955/0	ANELLO ELASTICO	SNAP RING	ANNEAU RESSORT	SPRENGRING	4
35	25670008/0	RONDELLA	WASHER	RONDELLE	SCHEIBE	2
36	12295200/0	DADO	NUT	ECROU	MUTTER	4
37	12156602/0	DADO	NUT	ECROU	MUTTER	4

PARTI DI RICAMBIO PER IL TRATTORINO
 SPARE PARTS FOR RIDER-ON-MOWERS
 PIECES DETACHEES POUR TONDEUSE AUTOPORTEE
 RASENTRAKTORERSATZTEILE

TC(P)
TC(P) hydro

Mod. 1998

008

GRUPPO PIATTO DI TAGLIO (1)
 CUTTING PLATE GROUP (1)
 GROUPE PLATEAU DE COUPE (1)
 SCHNEIDWERKZEUG (1)

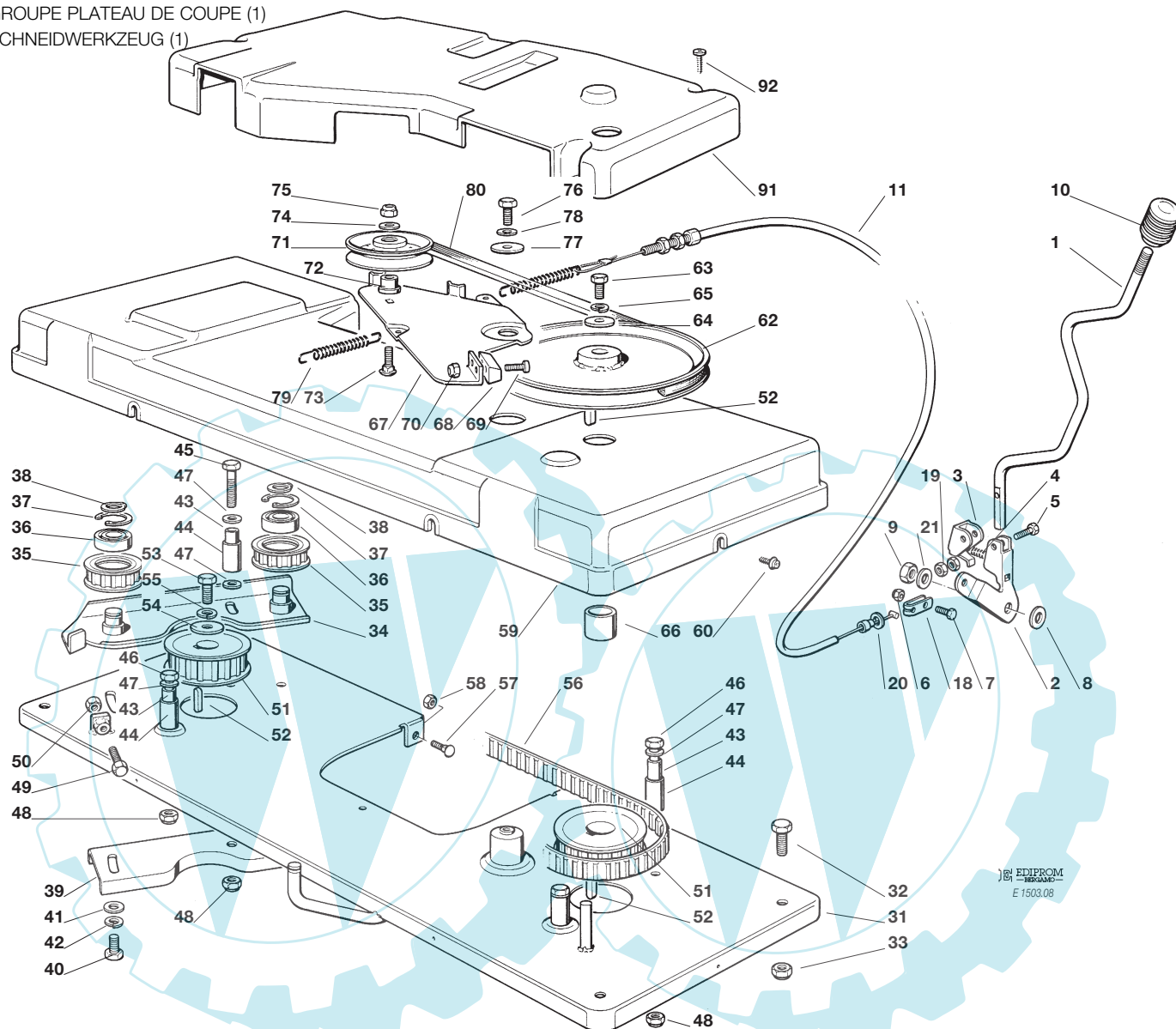

EDIPROM
 E 1503.08

Pos. Nr.	Codice Kodex Code	Descrizione	Description	Description	Beschreibung	Q.tà Q.ty Q.té Menge
1	25318120/0	LEVA INNESTO	ENGAGING LEVER	LEVIER D'EMBRAYAGE	EINSCHALTENHEBEL	1
2	82774209/0	STAFFA LEVA	CLAMP LEVER	BRIDE POUR LEVIER	BRIDE FÜR HEBEL	1
3	25774211/1	STAFFA MOLLA	CLAMP SPRING	BRIDE POUR RESSORT	BRIDE FÜR FEDER	1
4	25430206/1	MOLLA	SPRING	RESSORT	FEDER	1
5	12674550/0	VITE	SCREW	VIS	SCHRAUBE	1
6	12154510/0	DADO	NUT	ECROU	MUTTER	1
7	12791213/0	VITE	SCREW	VIS	SCHRAUBE	1
8	22672151/0	RONDELLA	WASHER	RONDELLE	SCHEIBE	1
9	12155010/0	DADO	NUT	ECROU	MUTTER	1
10	82394503/0	MANOPOLA	HANDLE	POIGNÉE	GRIF	1
11	82004601/1	ASSIEME FILO (TC(P) 102)	WIRE ASS.Y (TC(P) 102)	ENSEMBLE FIL (TC(P) 102)	KABEL (TC(P) 102)	1
	82004602/2	ASSIEME FILO (TC(P) 122)	WIRE ASS.Y (TC(P) 122)	ENSEMBLE FIL (TC(P) 122)	KABEL (TC(P) 122)	1
18	22061337/0	CAVALLOTTO	CONNECTING PLATE	PLAQUE DE CONNEXION	BUGEL BOLZEN	1
19	12292100/0	DADO	NUT	ECROU	MUTTER	2
20	12523040/0	RONDELLA	WASHER	RONDELLE	SCHEIBE	1
21	12523060/0	RONDELLA	WASHER	RONDELLE	SCHEIBE	1

Pos. Nr.	Codice Kodex Code	Descrizione	Description	Description	Beschreibung	Q.tà Q.ty Q.té Menge
31	82547003/1	PIASTRA (TC(P) 102)	PLATE (TC(P) 102)	PLATE (TC(P) 102)	PLATTE (TC(P) 102)	1
	82547005/0	PIASTRA (TC(P) 122)	PLATE (TC(P) 122)	PLATE (TC(P) 122)	PLATTE (TC(P) 122)	1
32	12792611/0	VITE	SCREW	VIS	SCHRAUBE	4
33	12293201/0	DADO	NUT	ECROU	MUTTER	4
34	82785084/1	SUPPORTO	SUPPORT	SUPPORT	HALTERSATZ	1
35	25601559/1	PULEGGIA (TC(P) 102)	PULLEY (TC(P) 102)	POULIE (TC(P) 102)	RIEMENSCHLEIBE (TC(P) 102)	2
	25601561/0	PULEGGIA (TC(P) 122)	PULLEY (TC(P) 122)	POULIE (TC(P) 122)	RIEMENSCHLEIBE (TC(P) 122)	2
36	19216033/1	CUSCINETTO	BEARING	ROULEMENT	KUEGELLAGER	2
37	12610800/0	SEEGER	SEEGER	SEEGER	SEEGER	2
38	12609200/0	SEEGER	SEEGER	SEEGER	SEEGER	2
39	25650037/0	RINF. PULEGGE	PULLEY STIFFENING	REINFORCEMENT DES POULIE	RIEMENSCHLEIBE VERSTAERKUNG	1
40	12793102/0	VITE	SCREW	VIS	SCHRAUBE	2
41	12521350/0	RONDELLA	WASHER	RONDELLE	SCHLEIBE	2
42	12583500/0	GROWER	GROWER	GROWER	GROWER	2
43	25160003/0	DISTANZIALE	SPACER	ENTRETOISE	DISTANZRING	4
44	25038000/0	BOCCOLA	BUSHING	DOUILLE	BUCHSE	4
45	12691700/0	VITE	SCREW	VIS	SCHRAUBE	1
46	12691200/0	VITE	SCREW	VIS	SCHRAUBE	3
47	12521350/0	RONDELLA	WASHER	RONDELLE	SCHLEIBE	5
48	12155000/0	DADO	NUT	ECROU	MUTTER	4
49	12793900/0	VITE	SCREW	VIS	SCHRAUBE	1
50	12293200/0	DADO	NUT	ECROU	MUTTER	1
51	25601560/0	PULEGGIA (TC(P) 102)	PULLEY (TC(P) 102)	POULIE (TC(P) 102)	RIEMENSCHLEIBE (TC(P) 102)	2
	25601562/0	PULEGGIA (TC(P) 122)	PULLEY (TC(P) 122)	POULIE (TC(P) 122)	RIEMENSCHLEIBE (TC(P) 122)	2
52	12139480/0	CHIAVETTA	KEY	CLAVETTE	KEIL	3
53	12793102/0	VITE	SCREW	VIS	SCHRAUBE	1
54	25670007/0	RONDELLA	WASHER	RONDELLE	SCHLEIBE	1
55	12583500/0	GROWER	GROWER	GROWER	GROWER	1
56	35065600/0	CINGHIA (TC(P) 102)	BELT (TC(P) 102)	COURROIRE (TC(P) 102)	KEILRIEMEN (TC(P) 102)	1
	35065601/0	CINGHIA (TC(P) 122)	BELT (TC(P) 122)	COURROIRE (TC(P) 122)	KEILRIEMEN (TC(P) 122)	1
57	12815200/0	VITE	SCREW	VIS	SCHRAUBE	3
58	12292102/0	DADO	NUT	ECROU	MUTTER	3
59	25060100/1	CARTER (TC(P) 102)	CASE (TC(P) 102)	CARTER (TC(P) 102)	BLECH (TC(P) 102)	1
	25060101/0	CARTER (TC(P) 122)	CASE (TC(P) 122)	CARTER (TC(P) 122)	BLECH (TC(P) 122)	1
60	12735110/0	VITE	SCREW	VIS	SCHRAUBE	6
62	25601550/0	PULEGGIA (TC(P) 102)	PULLEY (TC(P) 102)	POULIE (TC(P) 102)	RIEMENSCHLEIBE (TC(P) 102)	1
	25601549/0	PULEGGIA (TC(P) 122)	PULLEY (TC(P) 122)	POULIE (TC(P) 122)	RIEMENSCHLEIBE (TC(P) 122)	1
63	12793102/0	VITE	SCREW	VIS	SCHRAUBE	1
64	25670007/0	RONDELLA	WASHER	RONDELLE	SCHLEIBE	1
65	12583500/0	GROWER	GROWER	GROWER	GROWER	1
66	25160002/0	DISTANZIALE	SPACER	ENTRETOISE	DISTANZRING	1
67	25318115/0	LEVA FRENO (TC(P) 102)	BRAKE LEVER (TC(P) 102)	LEVIER FREIN (TC(P) 102)	BREMSHEBEL (TC(P) 102)	1
	25318119/0	LEVA FRENO (TC(P) 122)	BRAKE LEVER (TC(P) 122)	LEVIER FREIN (TC(P) 122)	BREMSHEBEL (TC(P) 122)	1
68	25207000/1	FERODO	LINING	PASTILLE FREIN	BREMSELAGE	1
69	12771400/0	VITE	SCREW	VIS	SCHRAUBE	2
70	12154330/0	DADO	NUT	ECROU	MUTTER	2
71	25601555/0	PULEGGIA	PULLEY	POULIE	RIEMENSCHLEIBE	1
72	25160007/0	DISTANZIALE	SPACER	ENTRETOISE	DISTANZRING	1
73	12818900/0	VITE	SCREW	VIS	SCHRAUBE	1
74	12523060/0	RONDELLA	WASHER	RONDELLE	SCHLEIBE	1
75	12155000/0	DADO	NUT	ECROU	MUTTER	1
76	12793102/0	VITE	SCREW	VIS	SCHRAUBE	1
77	12523070/0	RONDELLA	WASHER	RONDELLE	SCHLEIBE	1
78	12583500/0	GROWER	GROWER	GROWER	GROWER	1
79	25430210/0	MOLLA FRENO LAMA (TC(P) 102)	BLADE BRAKE SPRING (TC(P) 102)	RESSORT FREIN LAME (TC(P) 102)	MESSER BREMSE FEDER1 (TC(P) 102)	1
	25430220/0	MOLLA FRENO LAMA (TC(P) 122)	BLADE BRAKE SPRING (TC(P) 122)	RESSORT FREIN LAME (TC(P) 122)	MESSER BREMSE FEDER1 (TC(P) 122)	1
80	35062811/0	CINGHIA (TC(P) 102)	BELT (TC(P) 102)	COURROIE (TC(P) 102)	KEIL RIEMEN (TC(P) 102)	1
	35062812/0	CINGHIA (TC(P) 122)	BELT (TC(P) 122)	COURROIE (TC(P) 122)	KEIL RIEMEN (TC(P) 122)	1
91	25600000/0	PROTEZIONE CINGHIA POST. (TC(P) 102)	REAR BELT PROTECTION (TC(P) 102)	PROTECTION COURROIRE POSTERIEURE (TC(P) 102)	HINTERRIEMENSCHUTZ (TC(P) 102)	1
	25600008/0	PROTEZIONE CINGHIA POST. (TC(P) 122)	REAR BELT PROTECTION (TC(P) 122)	PROTECTION COURROIRE POSTERIEURE (TC(P) 122)	HINTERRIEMENSCHUTZ (TC(P) 122)	1
92	12735402/0	VITE	SCREW	VIS	SCHRAUBE	4

PARTI DI RICAMBIO PER IL TRATTORINO
 SPARE PARTS FOR RIDER-ON-MOWERS
 PIECES DETACHEES POUR TONDEUSE AUTOPORTEE
 RASENTRAKTORERSATZTEILE

TC(P)
TC(P) hydro

Mod. 1998

009

GRUPPO PIATTO DI TAGLIO (2)
 CUTTING PLATE GROUP (2)
 GROUPE PLATEAU DE COUPE (2)
 SCHNEIDWERKZEUG (2)

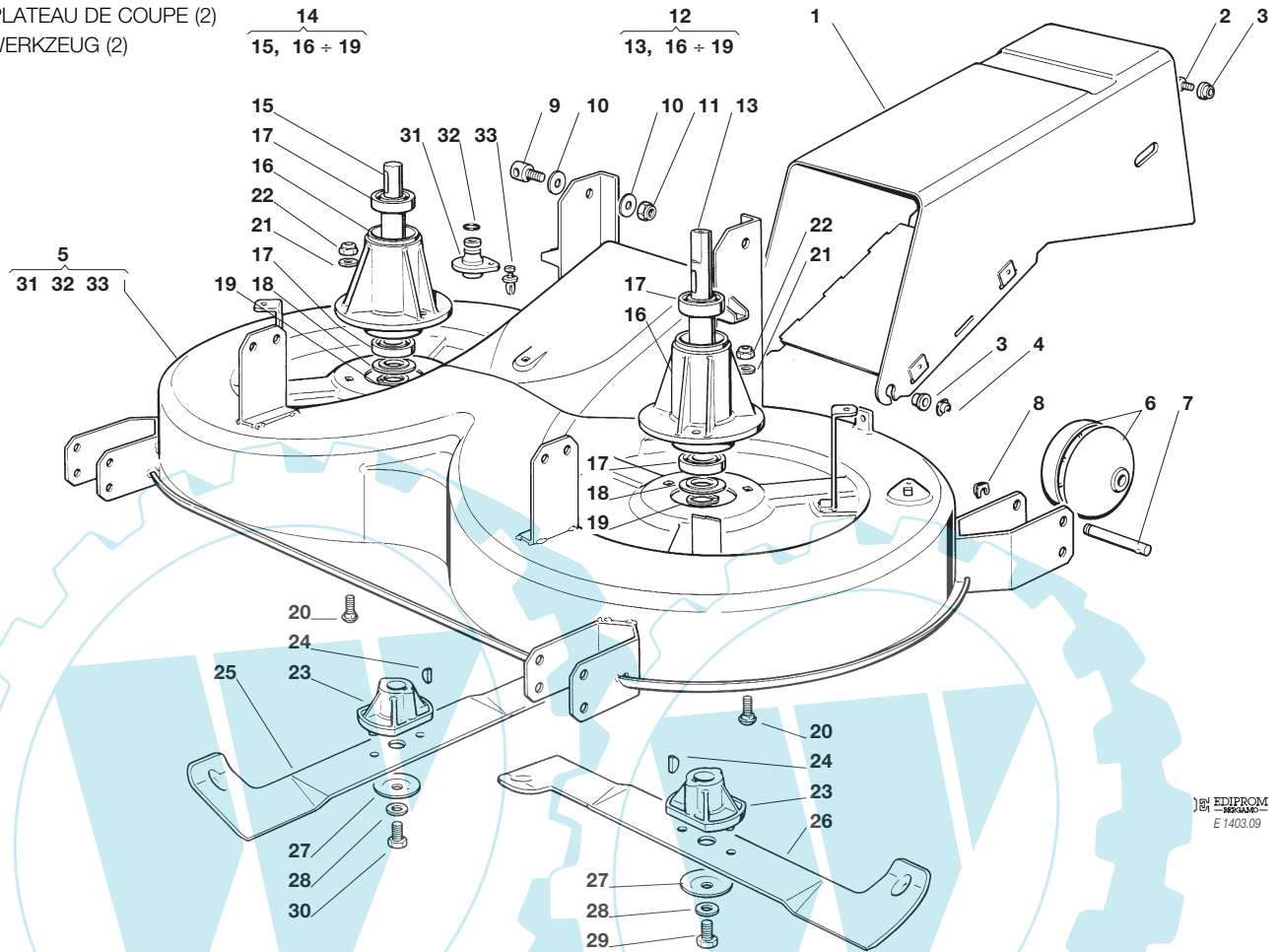

Pos. Nr.	Codice Kodex Code	Descrizione	Description	Description	Beschreibung	Q.tà Q.ty Q.té Menge
1	82108004/0	CONVOGLIATORE POSTER.	REAR CONVEYOR ASS.Y	ENS. CONVOYEUR POST.	HINTERLEITBLECHSATZ	1
2	12793102/0	VITE	SCREW	VIS	SCHRAUBE	2
3	25038002/0	BOCCOLA	BUSHING	DOUILLE	BUCHSE	4
4	12436050/0	PIASTRINA	PLATE	PLAQUE	PLATTE	2
5	82565005/0	ASSIEME PIATTO DI TAGLIO (+32-33-34) (TC(P) 102)	CUTTING PLATE ASS.Y (+32-33-34) (TC(P) 102)	ENS. PLATEAU DE COUPE (+32-33-34) (TC(P) 102)	SCHNEIDWERKZEUG (+32-33-34) (TC(P) 102)	1
	82565008/0	ASSIEME PIATTO DI TAGLIO (+32-33-34) (TC(P) 122)	CUTTING PLATE ASS.Y (+32-33-34) (TC(P) 122)	ENS. PLATEAU DE COUPE (+32-33-34) (TC(P) 122)	SCHNEIDWERKZEUG (+32-33-34) (TC(P) 122)	1
6	82700000/0	RUOTINO ANTISCALPO	LEVELLING SMALL WHEEL	PETITE ROUEDE INVEL-LEMENT	EBENUNGRAEDCHEN	4
7	25510006/0	PERNO	PIN	PIVOT	BOLZEN	4
8	12436030/0	PIASTRINA	PLATE	PLAQUE	PLATTE	4
9	25510024/0	PERNO	PIN	PIVOT	BOLZEN	4
10	25670008/0	RONDELLA	WASHER	RONDELLE	SCHEIBE	8
11	12156602/0	DADO	NUT	ECROU	MUTTER	4
12	82207200/0	ASS. FLANGIA ALBERO PRINCIPALE (13, 16÷19)	BLADE MAIN SHAFT SUPPORT (13, 16÷19)	SUPPORT ARBRE LAME PRINCIPAL (13, 16÷19)	MESSERWELLEHAFT-SATZ (13, 16÷19)	1
13	25020800/0	ALBERO LAMA PRINCIPALE	MAIN BLADE SHAFT	ARBRE LAME PRINCIPAL	HAUP MESSERWELLE	1
14	82207201/1	ASS. FLANGIA ALBERO SECONDARIO (15,16÷19)	BLADE SECONDARY SHAFT SUPPORT (15, 16÷19)	SUPPORT ARBRE LAME SECONDAIRE (15,16÷19)	MASSERWELLE ZWEITER-SATZ (15,16÷19)	1
15	25020801/1	ALBERO LAMA SECONDARIO	SECONDARY BLADE SHAFT	ARBRE LAME SECONDAIRE	ZWEITE MESSERWELLE	1
16	25207200/0	FLANGIA ALBERO LAMA	BLADE SHAFT SUPPORT	SUPPORT ARBRE LAME	MESSERWELLE	2
17	19216032/0	CUSCINETTO	BEARING	ROULEMENT	KUEGELLAGER	4
18	25160501/0	DISCO PARAPOLVERE	DUST COVER	PROTEGE-POUSSIERE	STAUBSCHUTTSCHIEBE	2
19	12609260/0	SEGER	SEGER	SEGER	SEGER	2
20	12818700/0	VITE	SCREW	VIS	SCHRAUBE	6

Pos. Nr.	Codice Kodex Code	Descrizione	Description	Description	Beschreibung	Q.tà Q.ty Q.té Menge
21	12521350/0	RONDELLA	WASHER	RONDELLE	SCHEIBE	6
22	12155000/0	DADO	NUT	ECROU	MUTTER	6
23	25463200/0	MOZZO COLTELLO	BLADE HUB	MOYEU LAME	MESSERHALTER	2
24	12139100/0	LINGUETTA	KEY	CLAVETTE	KEIL	2
25	82004341/0	COLTELLO DX (TC(P) 102)	RIGHT BLADE (TC(P) 102)	LAME DROITE (TC(P) 102)	RECHTER MESSER (TC(P) 102)	1
	82004343/0	COLTELLO DX (TC(P) 122)	RIGHT BLADE (TC(P) 122)	LAME DROITE (TC(P) 122)	RECHTER MESSER (TC(P) 122)	1
26	82004340/0	COLTELLO SX (TC(P) 102)	LEFT BLADE (TC(P) 102)	LAME GAUCHE (TC(P) 102)	LINKER MESSER (TC(P) 102)	1
	82004342/0	COLTELLO SX (TC(P) 122)	LEFT BLADE (TC(P) 122)	LAME GAUCHE (TC(P) 122)	LINKER MESSER (TC(P) 122)	1
27	22160400/0	DISCO ELASTICO	ELASTIC WASHER	RONDELLE ELASTIQUE	FEDERSCHEIBE	2
28	12523080/0	RONDELLA	WASHER	RONDELLE	SCHEIBE	2
29	12735694/0	VITE	SCREW	VIS	SCHRAUBE	1
30	12735695/1	VITE	SCREW	VIS	SCHRAUBE	1
31	25033060/0	ATTACCO TUBO ACQUA	WATER HOSE CONNECTION	RACCORD TUYAU D'EAU	WASSERANSCHLUSS	2
32	19035000/0	ANELLO OR	O RING	O RING	O RING	2
33	12500030/0	RIVETTO	RIVET	RIVET	NIET	2
—	82565000/1	PIATTO DI TAGLIO ASSEMBLATO (TC(P) 102) (008, 31÷92 + 009, 5÷33)	CUTTING PLATE, ASSEMBLED (TC(P) 102) (008, 31÷92 + 009, 5÷33)	PLATEAU DE COUPE,S COMPLETE (TC(P) 102) (008, 31÷92 + 009, 5÷33)	CHNEIDWERKZEUG, KOMPLETT (TC(P) 102) (008, 31÷92 + 009, 5÷33)	1
—	82565003/1	PIATTO DI TAGLIO, ASSEMBLATO (TC(P) 122) (008, 31÷92 + 009, 5÷33)	CUTTING PLATE, ASSEMBLED (TC(P) 122) (008, 31÷92 + 009, 5÷33)	PLATEAU DE COUPE,S COMPLETE (TC(P) 122) (008, 31÷92 + 009, 5÷33)	CHNEIDWERKZEUG, KOMPLETT (TC(P) 122) (008, 31÷92 + 009, 5÷33)	1

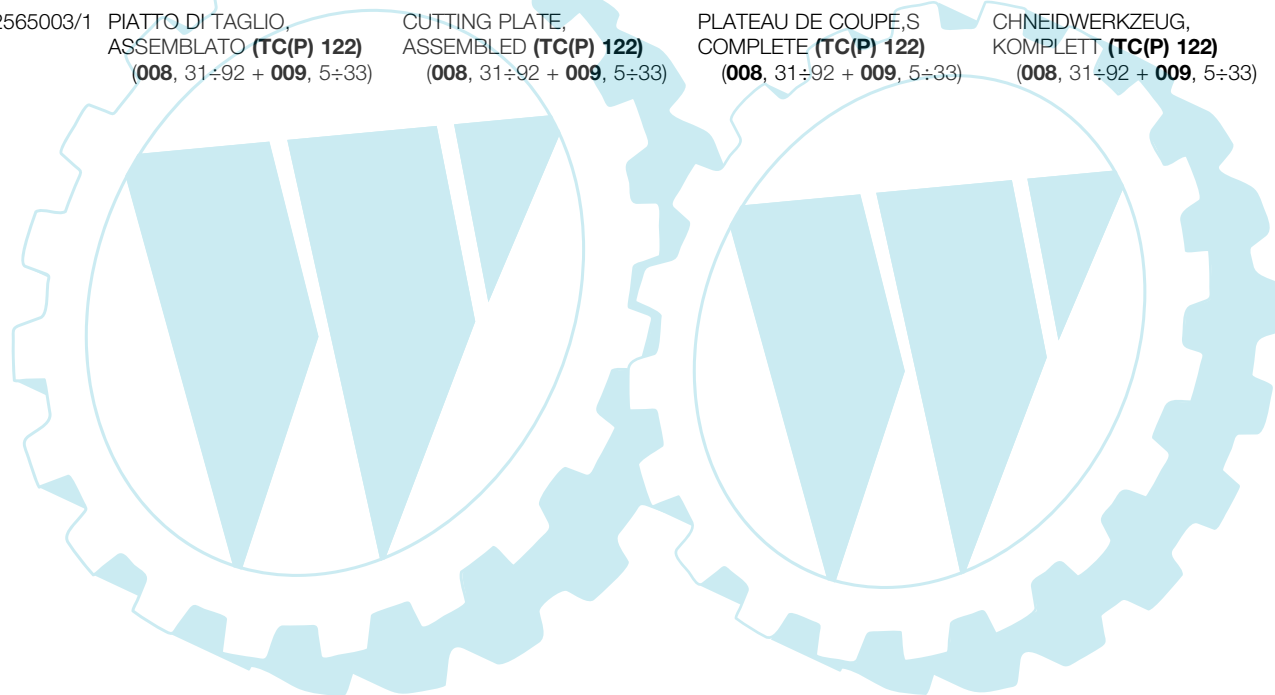

PARTI DI RICAMBIO PER IL TRATTORINO
 SPARE PARTS FOR RIDER-ON-MOWERS
 PIECES DETACHEES POUR TONDEUSE AUTOPORTEE
 RASENTRAKTORERSATZTEILE

TC(P)
TC(P) hydro

Mod. 1998

010

GRUPPO SOLLEVAMENTO SACCO E MICRO SACCO PIENO
 LIFTING DEVICE AND EMPTY GRASSCATCHER MICRO
 GROUPE SOULEVEMENT BAC ET MICRO BAC PLEIN
 AUSHEBENVORRICHTUNG UND VOLLKORB EIN RICHTUNG FÜR SACK

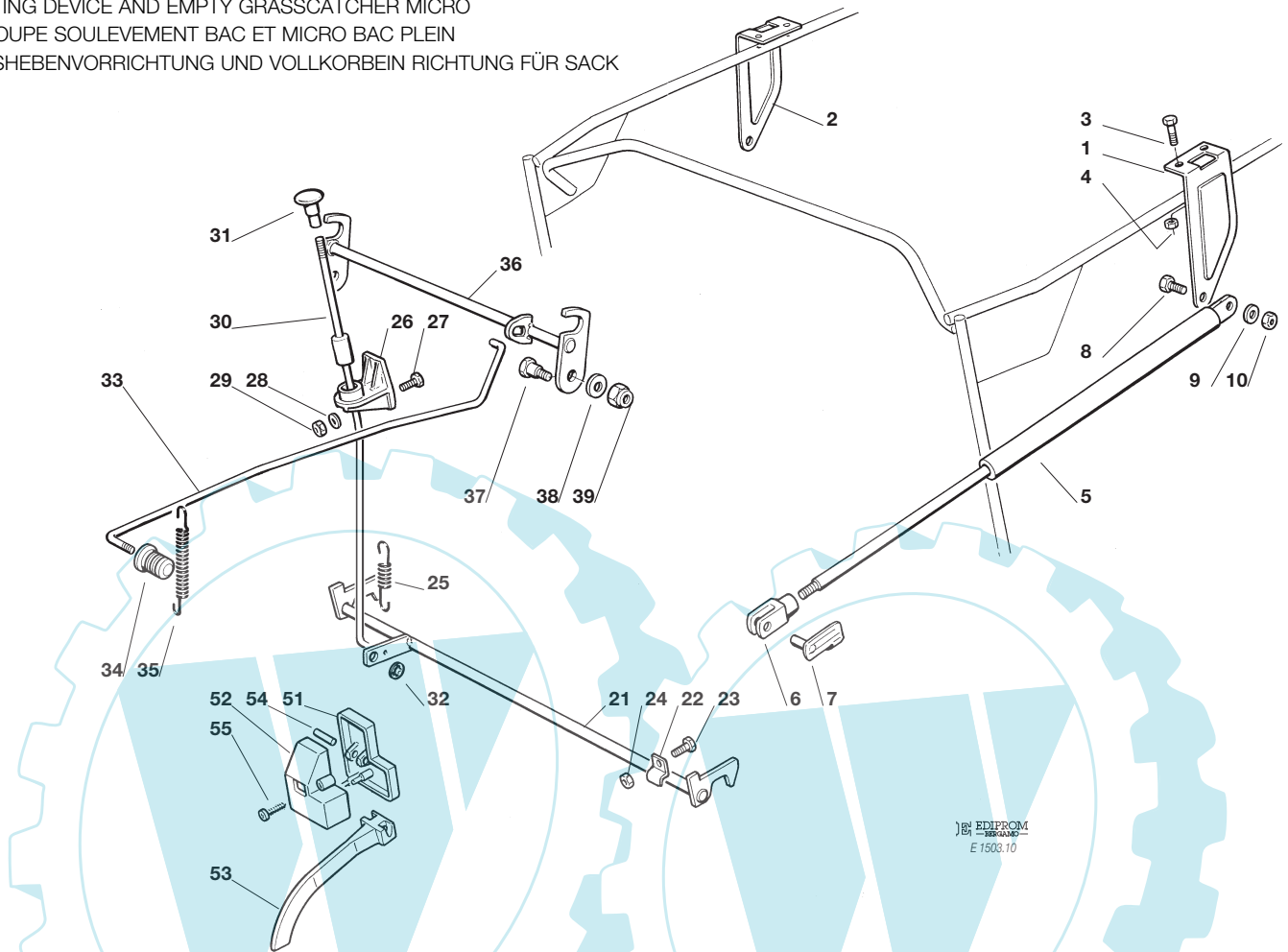

Pos. Nr.	Codice Kodex Code	Descrizione	Description	Description	Beschreibung	Q.tà Q.ty Q.té Menge
1	25547005/0	PIASTRA SX	LEFT PLATE	PLAQUE GAUCHE	LINKE PLATTE	1
2	25547007/0	PIASTRA DX	RIGHT PLATE	PLAQUE DROITE	RECHTE PLATTE	1
3	12792611/0	VITE	SCREW	VIS	SCHRAUBE	4
4	12293201/0	DADO	NUT	ECROU	MUTTER	4
5	18564600/0	PISTONE SOLLEVAMENTO	LIFTING PISTON	RESSORT A GAZ	GASFEDER	2
6	18399000/0	FORCELLA	FORK	FOURCHE	GABEL	2
7	18210200/0	CLIP	CLIP	CLIP	SPERRBOLZEN	2
8	12793101/0	VITE	SCREW	VIS	SCHRAUBE	2
9	12521350/0	ROSETTA	WASHER	RONDELLE	SCHEIBE	2
10	12155000/0	DADO	NUT	ECROU	MUTTER	2
21	82000357/0	ASTA AGGANCIAMENTO SACCO INF.	LOWER COUPLING ROD	TIGE D'ACCROCHAGE INF.	UTERE KUPPLUNGSTANGE	1
22	25774220/0	STAFFA ANCORAGGIO	ANCHOR BRACKET	ETRIER	BRIDE	2
23	12791200/0	VITE	SCREW	VIS	SCHRAUBE	4
24	12292102/0	DADO	NUT	ECROU	MUTTER	2
25	25430220/0	MOLLA	SPRING	RESSORT	FEDER	1
26	25785055/0	SUPPORTO GUIDA ASTA	SUPPORT	SUPPORT	SUPPORT	1
27	12791200/0	VITE	SCREW	VIS	SCHRAUBE	1
28	12521330/0	ROSETTA	WASHER	RONDELLE	SCHEIBE	1
29	12154510/0	DADO	NUT	ECROU	MUTTER	1
30	82000462/0	ASTA SGANCIO	RELEASE ROD	TIGE DE DECCROCHAGE	ENTKUPPLUNGSTANGE	1
31	82394507/0	MANOPOLA	HANDLE	POIGNEE	GRIF	1
32	12604898/0	RONDELLA DI RITEGNO	WASHER	RONDELLE	SCHEIBE	1
33	25033015/0	ASTA BLOCCAGGIO	LOCKING ROD	TIGE DE BLOCAGE	KLEMENSTANGE	1
	25033018/0	ASTA BLOCCAGGIO (hydro)	LOCKING ROD (hydro)	TIGE DE BLOCAGE (hydro)	KLEMENSTANGE (hydro)	1

Pos. Nr.	Codice Kodex Code	Descrizione	Description	Description	Beschreibung	Q.tà Q.ty Q.té Menge
34	82394500/0	MANOPOLA	HANDLE	POINGEE	GRIFF	1
35	25430213/0	MOLLA	SPRING	RESSORT	FEDER	1
36	82000355/0	ASTA AGGANCIAMENTO SACCOSUP.	UPPER COUPLING ROD	TIGE D'ACCROCHAGE SUP.	OBERE KUPLUNGSTANGE	1
37	25510038/0	PERNO	PIN	PIVOT	BOLZEN	2
38	12521350/0	ROSETTA	WASHER	RONDELLE	SCHEIBE	2
39	12155000/0	DADO	NUT	ECROU	MUTTER	2
51	25600014/0	COPERCHIO PROTEZIONE	PROTECTION	PROTECTION	SHUTZ	1
52	25600013/0	PROTEZIONE MICRO	MICRO PROTECTION	PROTECTION MICRO	SCHUTZ	1
53	25318112/0	LEVA	LEVER	LEVIER	HEBEL	1
54	12400030/0	PERNO	PIN	PIVOT	BOLZEN	1
55	12728440/0	VITE	SCREW	VIS	SCHRAUBE	2

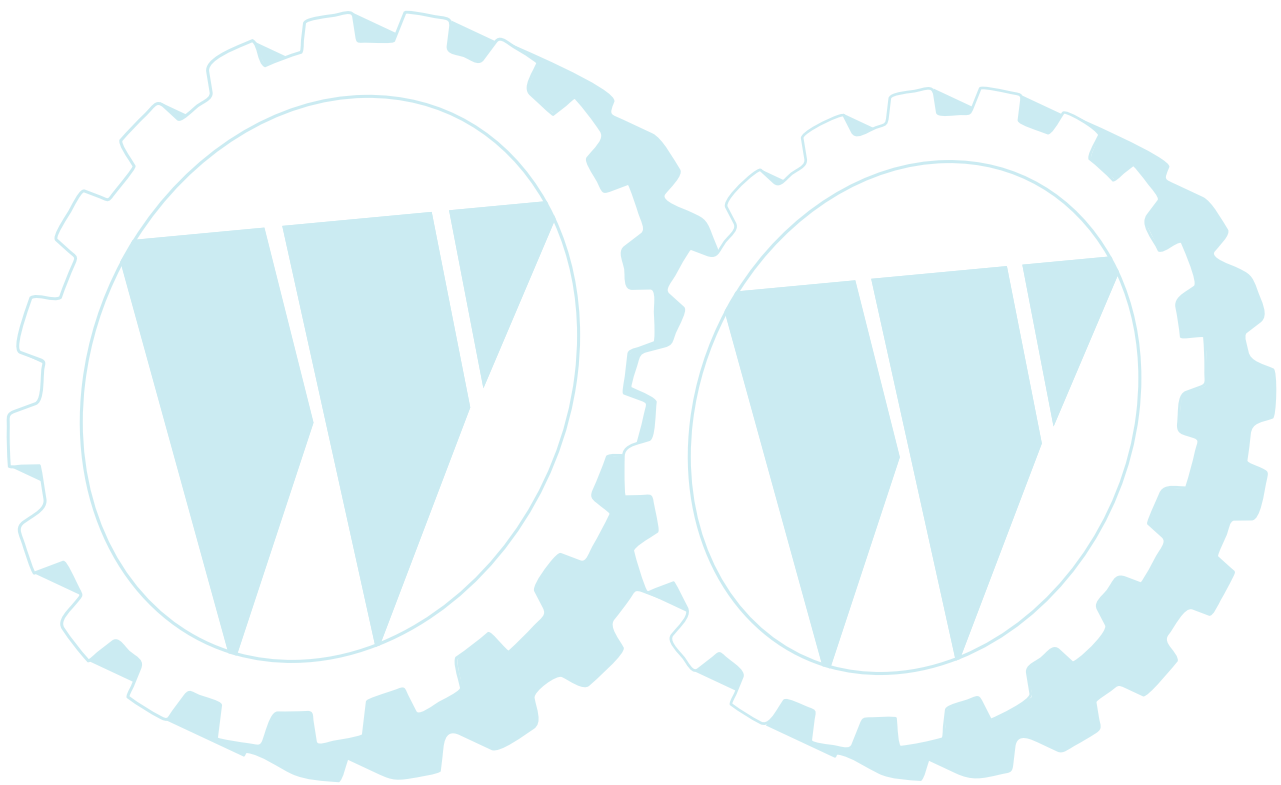

PARTI DI RICAMBIO PER IL TRATTORINO
 SPARE PARTS FOR RIDER-ON-MOWERS
 PIECES DETACHEES POUR TONDEUSE AUTOPORTEE
 RASENTRAKTORERSATZTEILE

TC(P)

GRUPPO PARTI ELETTRICHE
 ELECTRICAL PARTS GROUP
 GROUPE PARTIES ELECTRIQUES
 ELETRISCHETEILE

Mod. 1998

011

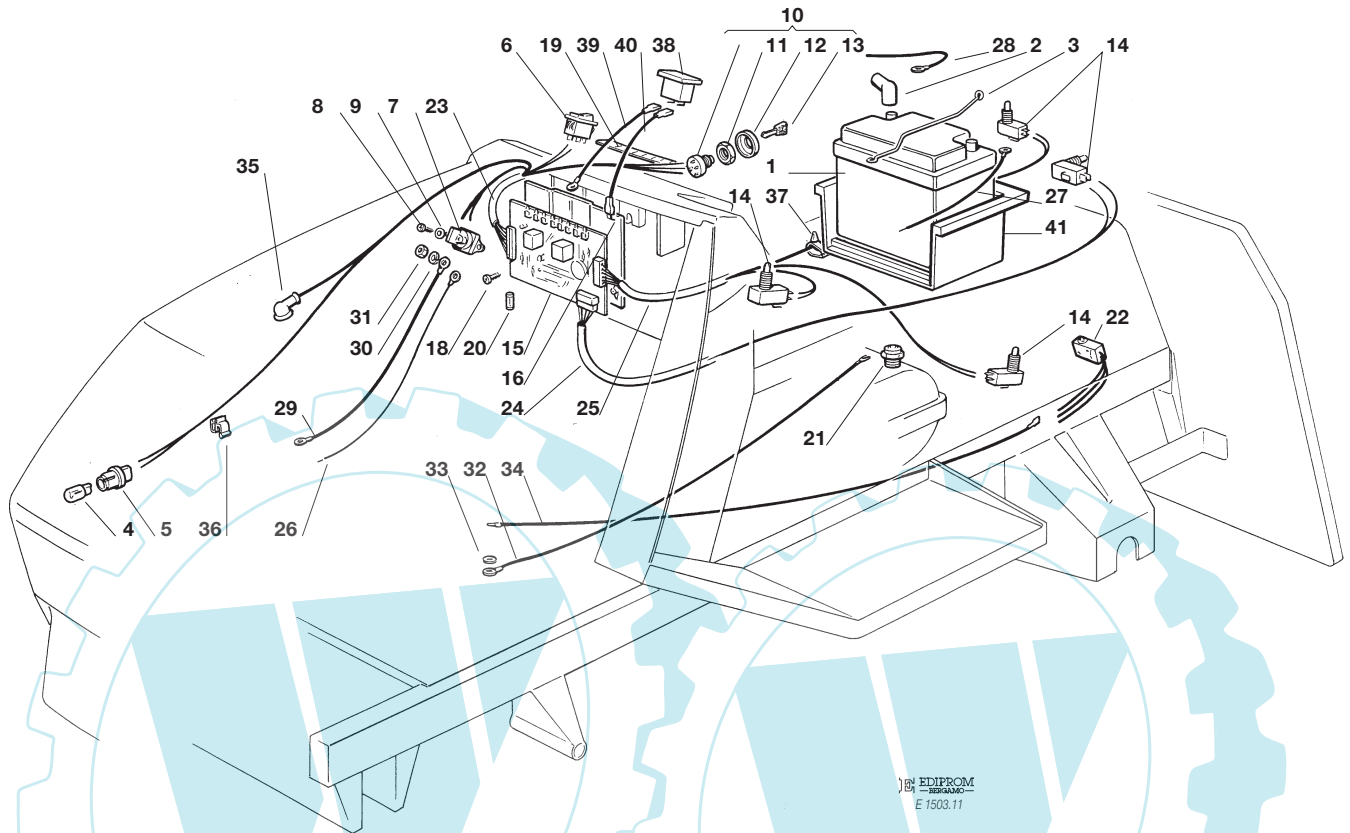

Pos. Nr.	Codice Kodex Code	Descrizione	Description	Description	Beschreibung	Q.tà Q.ty Q.té Menge
1	18120002/1	BATTERIA 12 V - 18 Ah	BATTERY 12 V - 18 Ah	BATTERIE 12 V - 18 Ah	BATTERIE 12 V - 18 Ah	1
2	18564862/0	PROTEZIONE	PROTECTION	PROTECTION	SCHUTZ	1
3	25430200/0	MOLLA	SPRING	RESSORT	FEDER	2
4	18459100/0	LAMPADA	FARILAMP FOR LIGHTS	LAMPE POUR PHARES	LAMPENFASSUN	2
5	33500030/0	PORTALAMPADE	LAMP HOLDER	DOUILLE DE LAMPE	SCHENWERFERLAMPE	2
6	18450060/0	INTERRUTTORE	FARILAMP SWITCH	INTERRUPTEUR PHARES	LICHTEN SCHALTER	1
7	18736110/0	SOLENOIDE	SOLENOID	SOLENOIDE	SOLENOID	1
8	12728510/0	VITE	SCREW	VIS	SCHRAUBE	2
9	12521320/0	RONDELLA	WASHER	RONDELLE	SCHEIBE	2
10	18450065/1	INTERRUTTORE AVVIAMENTO	STARTING SWITCH	INTERRUPTEUR DEMARRAGE	SCHALTER	1
11	18400861/0	GHIERA	SCREWED RING	EMBOUT	NUTMUTTER	1
12	18565351/0	PROTEZIONE GHIERA	SCREWED RING PROTECTION	PROTECTION EMBOUT	NUTMUTTER SCHUTZ	1
13	18210016/0	CHIAVE AVVIAMENTO	STARTING KEY	CLEF A DEMARRAGE	SCHLÜSSEL FÜR START	1
14	19410603/1	MICRO INTERRUTTORE	MICRO	MICRO	MIKRO	4
15	***	SCHEDA ELETTRONICA	ELECTRONIC CARD	CARTE ELECTRONIQUE	ELEKTRONISCHE KARTE	1
16	25600007/0	PROTEZIONE SCHEDA (TC)	CARD PROTECTION (TC)	PROTECTION CARTE (TC)	KARTESCHUTZ (TC)	1
16	25600009/0	PROTEZIONE SCHEDA (TCP)	CARD PROTECTION (TCP)	PROTECTION CARTE (TCP)	KARTESCHUTZ (TCP)	1
18	12735105/0	VITE	SCREW	VIS	SCHRAUBE	3
19	25420000/1	MEMBRANA (6 FUNZ.)	CHECK CONTROLL (6 FUNCTIONS)	PANNEAU DE CONTROLE (6 INDICATIONS)	KONTROLLTAFEL (6 ANGABEN)	1
	25420001/1	MEMBRANA (8 FUNZ.)	CHECK CONTROLL (8 FUNCTIONS)	PANNEAU DE CONTROLE (8 INDICATIONS)	KONTROLLTAFEL (8 ANGABEN)	1
20	33340033/0	FUSIBILE 6,3 Amp. T	FUSE 6.3 Amp. T	FUSIBLE 6,3 Amp. T	SICHERUNG 6,3 Amp. T	1
21	19410604/0	INTERRUTTORE CAMBIO	GEARBOX SWITCH	INT. BOÎTE DE VITESSE	ANTRIEB SCHALTER	1
22	25425000/1	MICRO SACCO PIENO	FULL GRASSCATCHER MICROSWITCH	MICRO BAC PLEIN	VOLLKORB VORRICHTUNG	1

Pos. Nr.	Codice Kodex Code	Descrizione	Description	Description	Beschreibung	Q.tà Q.ty Q.té Menge
23	82040024/0	ASS. CABLAGGIO 12,5 HP B&S 13 - 15 HP TECUMSEH	CABLES ASS.Y 12,5 HP B&S 13 - 15 HP TECUMSEH	ENS. CABLAGES 12,5 HP B&S 13 - 15 HP TECUMSEH	KABELSATZ 12,5 HP B&S 13 - 15 HP TECUMSEH	1
	82040026/0	16 HP B&S	16 HP B&S	16 HP B&S	16 HP B&S	
	82040025/0	15,5HP B&S	15,5HP B&S	15,5HP B&S	15,5HP B&S	
24	82040004/1	ASS. CABLAGGIO 12,5 - 15,5 HP B&S 13 - 15 HP TECUMSEH	CABLES ASS.Y 12,5 - 15,5 HP B&S 13 - 15 HP TECUMSEH	ENS. CABLAGES 12,5 - 15,5 HP B&S 13 - 15 HP TECUMSEH	KABELSATZ 12,5 - 15,5 HP B&S 13 - 15 HP TECUMSEH	1
	82040005/1	16 - 18 HP B&S	16 - 18 HP B&S	16 - 18 HP B&S	16 - 18 HP B&S	
25	***	ASS. CABLAGGIO	CABLES ASS.Y	ENS. CABLAGES	KABELSATZ	1
26	25065003/0	CAVO RICARICA 12,5 - 15,5 - 16 - 18 HP B&S 13 - 15 HP TECUMSEH	CABLE 12,5 - 15,5 - 16 - 18 HP B&S 13 - 15 HP TECUMSEH	CABLES 12,5 - 15,5 - 16 - 18 HP B&S 13 - 15 HP TECUMSEH	KABEL 12,5 - 15,5 - 16 - 18 HP B&S 13 - 15 HP TECUMSEH	1
27	25065004/0	CAVO MASSA BATTERIA	CABLE	CABLES	KABEL	1
28	25065001/0	CAVO BATT. SOLENOIDE	CABLE	CABLES	KABEL	1
29	25065002/0	CAVO SOLENOIDE MOT.	CABLE	CABLES	KABEL	1
30	12583500/0	GROWER	GROWER	GROWER	GROWER	2
31	12360352/0	DADO	NUT	ECROU	MUTTER	2
32	25065005/0	CAVO MASSA	CABLE	CABLES	KABEL	1
33	12540260/0	RONDELLA	WASHER	RONDELLE	SCHIEBE	1
34	***	CAVO COLL. MICRO	CABLE	CABLES	KABEL	1
35	18564861/0	CAPPUCCIO PROTEZIONE	PROTECTION	PROTECTION	SCHUTZ	1
36	33320505/0	FERMACAVO	FAIRLED	FIXATION CABLE	KABELBEFESTIGUNG	1
37	33320506/0	FERMACAVO	FAIRLED	FIXATION CABLE	KABELBEFESTIGUNG	2
38	18230000/0	CONTORE (TCP)	HOUR COUNTER (TCP)	COMPTE-HEURS (TCP)	BETRIEBESSTUNDENZÄHLER (TCP)	1
39	25065009/0	CAVO (TCP)	CABLE (TCP)	CABLES (TCP)	KABEL (TCP)	1
40	25065010/1	CAVO (TCP)	CABLE (TCP)	CABLES (TCP)	KABEL (TCP)	1
41	25785010/0	SUPPORTO BATTERIA	BATTERY HOLDER	SUPPORT BATTERIE	BATTERIE STÜTZE	1

*** PER I PARTICOLARI CONTRASSEGNA TI, VERIFICARE L'ALLESTIMENTO DEL TRATTORINO:
 FOR THE MARKED ITEMS, PLEASE CHECK TRACTOR'S VERSION:
 POUR LES PIÉCES MARQUEES, VERIFIEZ LA VERSION DE L'AUTOPORTEE:
 FÜR KENNENZEICHNETEN TEILE, BITTE PRÜFEN SIE DER AUFSITZMÄHERAUSSTATTUNG:

a) **Motore 12,5 - 15,5 HP B&S, 13 - 15 HP Tecumseh + Interruttore cambio (21) + Micro sacco pieno (22)**
Engine 12,5 - 15,5 HP B&S, 13 - 15 HP Tecumseh + Gearbox switch (21) + Full grasscatcher micriswitch (22)
Moteur 12,5 - 15,5 HP B&S, 13 - 15 HP Tecumseh + Interrupteur boîte de vitesse (21) + Micro bac plein (22)
Motor 12,5 - 15,5 HP B&S, 13 - 15 HP Tecumseh + Antrieb Schalter (21) + Vollkorb Vorrichtung (22)

15	25722406/0	SCHEDA ELETTRONICA 6 FUNZIONI	ELECTRONIC CARD 6 FUNCTIONS	CARTE ELECTRONIQUE 6 INDICAT	ELEKTRONISCHE KARTE 6 ANGABEN	1
25	82040029/1	ASS. CABLAGGIO	CABLES ASS.Y	ENS. CABLAGES	KABELSATZ	1
34	25065011/0	CAVO COLL. MICRO	CABLE	CABLES	KABEL	1

b) **Motore 16 - 18 HP B&S + Interruttore cambio (21) + Micro sacco pieno (22)**
Engine 16 - 18 HP B&S + Gearbox switch (21) + Full grasscatcher micriswitch (22)
Moteur 16 - 18 HP B&S + Interrupteur boîte de vitesse (21) + Micro bac plein (22)
Motor 16 - 18 HP B&S + Antrieb Schalter (21) + Vollkorb Vorrichtung (22)

15	25722407/0	SCHEDA ELETTRONICA 8 FUNZIONI	ELECTRONIC CARD 8 FUNCTIONS	CARTE ELECTRONIQUE 8 INDICAT	ELEKTRONISCHE KARTE 8 ANGABEN	1
25	82040028/1	ASS. CABLAGGIO	CABLES ASS.Y	ENS. CABLAGES	KABELSATZ	1
34	25065011/0	CAVO COLL. MICRO	CABLE	CABLES	KABEL	1

PARTI DI RICAMBIO PER IL TRATTORINO
 SPARE PARTS FOR RIDER-ON-MOWERS
 PIECES DETACHEES POUR TONDEUSE AUTOPORTEE
 RASENTRAKTORERSATZTEILE

TC(P) hydro

GRUPPO PARTI ELETTRICHE
 ELECTRICAL PARTS GROUP
 GROUPE PARTIES ELECTRIQUES
 ELETRISCHETEILE

Mod. 1998 **011.1**

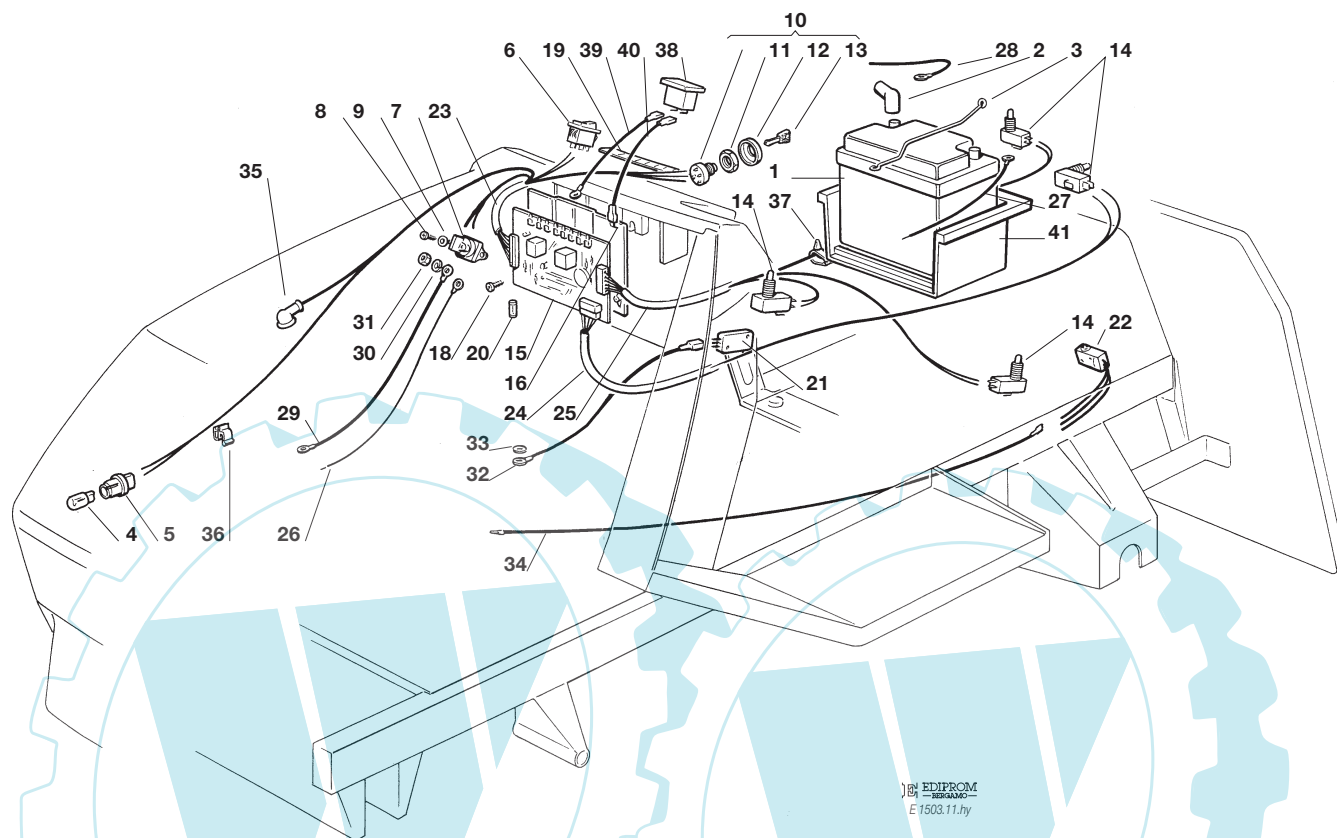

Pos. Nr.	Codice Kodex Code	Descrizione	Description	Description	Beschreibung	Q.tà Q.ty Q.té Menge
1	18120002/1	BATTERIA 12 V - 18 Ah	BATTERY 12 V - 18 Ah	BATTERIE 12 V - 18 Ah	BATTERIE 12 V - 18 Ah	1
2	18564862/0	PROTEZIONE	PROTECTION	PROTECTION	SCHUTZ	1
3	25430200/0	MOLLA	SPRING	RESSORT	FEDER	2
4	18459100/0	LAMPADA	FARILAMP FOR LIGHTS	LAMPE POUR PHARES	LAMPENFASSUN	2
5	33500030/0	PORTALAMPADE	LAMP HOLDER	DOUILLE DE LAMPE	SCHENWERFERLAMPE	2
6	18450060/0	INTERRUTTORE	FARILAMP SWITCH	INTERRUPTEUR PHARES	LICHTEN SCHALTER	1
7	18736110/0	SOLENOIDE	SOLENOID	SOLENOIDE	SOLENOID	1
8	12728510/0	VITE	SCREW	VIS	SCHRAUBE	2
9	12521320/0	RONDELLA	WASHER	RONDELLE	SCHEIBE	2
10	18450065/1	INTERRUTTORE AVVIAMENTO	STARTING SWITCH	INTERRUPTEUR DEMARRAGE	SCHALTER	1
11	18400861/0	GHIERA	SCREWED RING	EMBOUT	NUTMUTTER	1
12	18565351/0	PROTEZIONE GHIERA	SCREWED RING PROTECTION	PROTECTION EMBOUT	NUTMUTTER SCHUTZ	1
13	18210016/0	CHIAVE AVVIAMENTO	STARTING KEY	CLEF A DEMARRAGE	SCHLÜSSEL FÜR START	1
14	19410603/1	MICRO INTERRUTTORE	MICRO	MICRO	MIKRO	4
15	***	SCHEDA ELETTRONICA	ELECTRONIC CARD	CARTE ELECTRONIQUE	ELEKTRONISCHE KARTE	1
16	25600007/0	PROTEZIONE SCHEDA (TC)	CARD PROTECTION (TC)	PROTECTION CARTE (TC)	KARTESCHUTZ (TC)	1
16	25600009/0	PROTEZIONE SCHEDA (TCP)	CARD PROTECTION (TCP)	PROTECTION CARTE (TCP)	KARTESCHUTZ (TCP)	1
18	12735105/0	VITE	SCREW	VIS	SCHRAUBE	3
19	25420000/1	MEMBRANA (6 FUNZ.)	CHECK CONTROLL (6 FUNCTIONS)	PANNEAU DE CONTROLE (6 INDICATIONS)	KONTROLLTAFEL (6 ANGABEN)	1
	25420001/1	MEMBRANA (8 FUNZ.)	CHECK CONTROLL (8 FUNCTIONS)	PANNEAU DE CONTROLE (8 INDICATIONS)	KONTROLLTAFEL (8 ANGABEN)	1
20	33340033/0	FUSIBILE 6,3 Amp. T	FUSE 6.3 Amp. T	FUSIBLE 6,3 Amp. T	SICHERUNG 6,3 Amp. T	1
21	19410609/0	INTERRUT. POS. FOLLE	NEUTRAL SWITCH	INTERRUPT. POINT MORT	LEERLAUF SCHALTER	1
22	25425000/1	MICRO SACCO PIENO	FULL GRASSCATCHER MICROSWITCH	MICRO BAC PLEIN	VOLLKORB VORRICHTUNG	1

Pos. Nr.	Codice Kodex Code	Descrizione	Description	Description	Beschreibung	Q.tà Q.ty Q.té Menge
23	82040046/0	ASS. CABLAGGIO 12,5 HP B&S 13 - 15 HP TECUMSEH	CABLES ASS.Y 12,5 HP B&S 13 - 15 HP TECUMSEH	ENS. CABLAGES 12,5 HP B&S 13 - 15 HP TECUMSEH	KABELSATZ 12,5 HP B&S 13 - 15 HP TECUMSEH	1
	82040035/0	16 HP B&S	16 HP B&S	16 HP B&S	16 HP B&S	
	82040034/0	15,5HP B&S	15,5HP B&S	15,5HP B&S	15,5HP B&S	
24	82040004/1	ASS. CABLAGGIO 12,5 - 15,5 HP B&S 13 - 15 HP TECUMSEH	CABLES ASS.Y 12,5 - 15,5 HP B&S 13 - 15 HP TECUMSEH	ENS. CABLAGES 12,5 - 15,5 HP B&S 13 - 15 HP TECUMSEH	KABELSATZ 12,5 - 15,5 HP B&S 13 - 15 HP TECUMSEH	1
	82040005/1	16 - 18 HP B&S	16 - 18 HP B&S	16 - 18 HP B&S	16 - 18 HP B&S	
25	25065003/0	ASS. CABLAGGIO CAVO RICARICA 12,5 - 15,5 - 16 - 18 HP B&S 13 - 15 HP TECUMSEH	CABLES ASS.Y CABLE 12,5 - 15,5 - 16 - 18 HP B&S 13 - 15 HP TECUMSEH	ENS. CABLAGES CABLES 12,5 - 15,5 - 16 - 18 HP B&S 13 - 15 HP TECUMSEH	KABELSATZ KABEL 12,5 - 15,5 - 16 - 18 HP B&S 13 - 15 HP TECUMSEH	1
26	25065004/0	CAVO MASSA BATTERIA	CABLE	CABLES	KABEL	1
28	25065001/0	CAVO BATT. SOLENOIDE	CABLE	CABLES	KABEL	1
29	25065002/0	CAVO SOLENOIDE MOT.	CABLE	CABLES	KABEL	1
30	12583500/0	GROWER	GROWER	GROWER	GROWER	2
31	12360352/0	DADO	NUT	ECROU	MUTTER	2
32	25065015/0	CAVO MASSA	CABLE	CABLES	KABEL	1
33	12540260/0	RONDELLA	WASHER	RONDELLE	SCHIBE	1
34	18564861/0	CAVO COLL. MICRO	CABLE	CABLES	KABEL	1
35	33320505/0	CAPPUCCIO PROTEZIONE	PROTECTION	PROTECTION	SCHUTZ	1
36	33320506/0	FERMACAVO	FAIRLED	FIXATION CABLE	KABELBEFESTIGUNG	1
37	18230000/0	FERMACAVO	FAIRLED	FIXATION CABLE	KABELBEFESTIGUNG	2
38	25065009/0	CONTORE (TCP)	HOUR COUNTER (TCP)	COMPTE-HEURS (TCP)	BETRIEBESSTUNDENZÄHLER (TCP)	1
39	25065010/1	CAVO (TCP)	CABLE (TCP)	CABLES (TCP)	KABEL (TCP)	1
40	25785010/0	CAVO (TCP)	CABLE (TCP)	CABLES (TCP)	KABEL (TCP)	1
41	25785010/0	SUPPORTO BATTERIA	BATTERY HOLDER	SUPPORT BATTERIE	BATTERIE STÜTZE	1

*** PER I PARTICOLARI CONTRASSEGNA TI, VERIFICARE L'ALLES TI MENTO DEL TRATTO RINO:
 FOR THE MARKED ITEMS, PLEASE CHECK TRACTOR'S VERSION:
 POUR LES PI ECES MARQUEES, VERIFIEZ LA VERSION DE L'AUTO PORTEE:
 FÜR KENNENGEZEICHNETEN TEILE, BITTE PRÜFEN SIE DER AUFSITZMÄHERAUSSTATTUNG:

a) **Motore 12,5 - 15,5 HP B&S, 13 - 15 HP Tecumseh + Interruttore posizione folle (21) + Micro sacco pieno (22)**
Engine 12,5 - 15,5 HP B&S, 13 - 15 HP Tecumseh + Neutral switch (21) + Full grasscatcher micriswitch (22)
Moteur 12,5 - 15,5 HP B&S, 13 - 15 HP Tecumseh + Interrupteur point mort (21) + Micro bac plein (22)
Motor 12,5 - 15,5 HP B&S, 13 - 15 HP Tecumseh + Leerlaufstellung Schalter (21) + Vollkorb Vorrichtung (22)

15	25722406/0	SCHEDA ELETTRONICA 6 FUNZIONI	ELECTRONIC CARD 6 FUNCTIONS	CARTE ELECTRONIQUE 6 INDICAT	ELEKTRONISCHE KARTE 6 ANGABEN	1
25	82040029/1	ASS. CABLAGGIO	CABLES ASS.Y	ENS. CABLAGES	KABELSATZ	1
34	25065011/0	CAVO COLL. MICRO	CABLE	CABLES	KABEL	1

b) **Motore 16 - 18 HP B&S + Interruttore posizione folle (21) + Micro sacco pieno (22)**
Engine 16 - 18 HP B&S + Neutral switch (21) + Full grasscatcher micriswitch (22)
Moteur 16 - 18 HP B&S + Interrupteur point mort (21) + Micro bac plein (22)
Motor 16 - 18 HP B&S + Leerlaufstellung Schalter (21) + Vollkorb Vorrichtung (22)

15	25722407/0	SCHEDA ELETTRONICA 8 FUNZIONI	ELECTRONIC CARD 8 FUNCTIONS	CARTE ELECTRONIQUE 8 INDICAT	ELEKTRONISCHE KARTE 8 ANGABEN	1
25	82040028/1	ASS. CABLAGGIO	CABLES ASS.Y	ENS. CABLAGES	KABELSATZ	1
34	25065011/0	CAVO COLL. MICRO	CABLE	CABLES	KABEL	1

PARTI DI RICAMBIO PER IL TRATTORINO
 SPARE PARTS FOR RIDER-ON-MOWERS
 PIECES DETACHEES POUR TONDEUSE AUTOPORTEE
 RASENTRAKTORERSATZTEILE

TC(P)
TC(P) hydro

Mod. 1998

012

GRUPPO SACCO
 GRASSCATCHER GROUP
 GROUPE SAC
 GRASFANGEINRICHTUNG

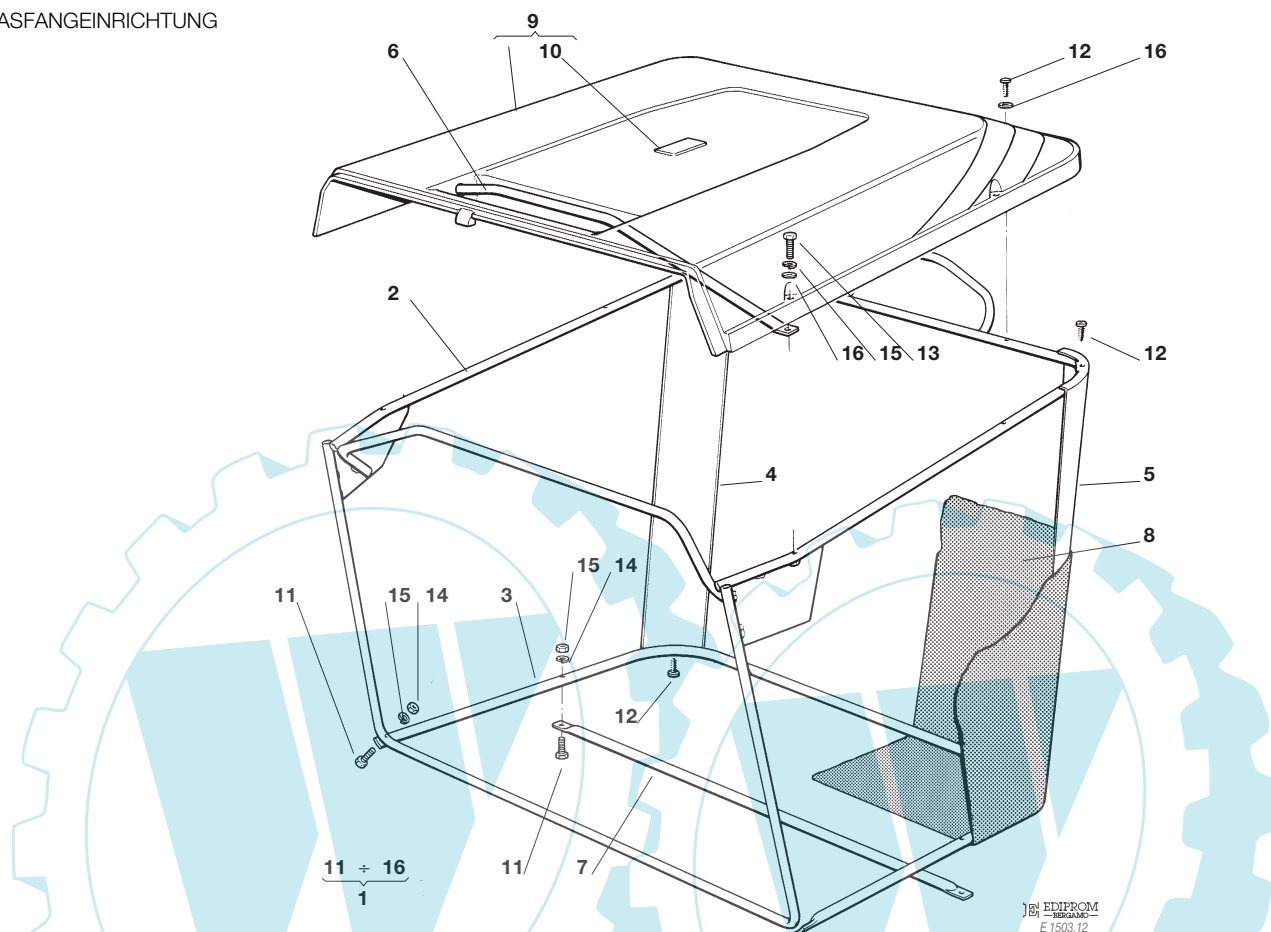

Pos. Nr.	Codice Kodex Code	Descrizione	Description	Description	Beschreibung	Q.tà Q.ty Q.té Menge
1	82180000/2	DOTAZIONE SACCO	GRASS-BOX OUTFIT	DOTATION BAC	KORBAUS TATTUNG	1
2	82800008/0	TELAIO SUP.	UPPER FRAME	CHASSIS SUPERIEUR	OBERERRAHMEN	1
3	82800002/0	TELAIO INF.	LOWER FRAME	CHASSIS INFÉRIEUR	UNTERERRAHMEN	1
4	25032001/1	ANGOLARE DX	RIGHT ANGULAR SUPPORT	SUPPORT ANGULAIRE DROITE	RECHTER HALTER	1
5	25032002/1	ANGOLARE SX	LEFT ANGULAR SUPPORT	SUPPORT ANGULAIRE GAUCHE	LINKER HALTER	1
6	82394001/0	MANIGLIA ANT.	FRONT HANDLE	POIGNEE ANTERIEURE	VORDERGRIFF	1
7	82650038/0	RINFORZO INF.	LOWER STIFFENING	RENFORCEMENT SUPER.	OBERE VERSTAERKUNG	1
8	821106000/1	SACCO	GRASSCATCHER	SAC	SACK	1
9	☛	COPERTURA SACCO (TC)	GRASSSCAT. PLASTIC (TC)	SAC COUVERTURE (TC)	SACKABDECKUNG (TC)	1
	82110158/1	ROSSA	RED	ROUGE	ROT	
	82110159/0	VERDE	GREEN)	VERT	GRÜN	
	82110160/0	GIALLA	YELLOW	JAUNE	GELB	
	82110161/0	BLU	BLUE	BLEU	BLAU	
	☛	COPERTURA SACCO (TCP)	GRASSSCAT. PLASTIC (TCP)	SAC COUVERTURE (TCP)	SACKABDECKUNG (TCP)	1
	82110170/0	ROSSA	RED	ROUGE	ROT	
	82110171/0	VERDE	GREEN)	VERT	GRÜN	
	82110172/0	GIALLA	YELLOW	JAUNE	GELB	
	82110173/0	BLU	BLUE	BLEU	BLAU	
10	☛	PIASTRINA (TC)	PLATE (TC)	PLAQUE (TC)	PLATTE (TC)	1
	25547016/1	ROSSA	RED	ROUGE	ROT	
	25547015/0	VERDE	GREEN	VERT	GRÜN	
	25547014/0	GIALLA	YELLOW	JAUNE	GELB	
	25547024/0	BLU	BLUE	BLEU	BLAU	

Pos. Nr.	Codice Kodex Code	Descrizione	Description	Description	Beschreibung	Q.tà Q.ty Q.té Menge
	←	PIASTRINA (TCP)	PLATE (TCP)	PLAQUE (TCP)	PLATTE (TCP)	1
	25547025/0	ROSSA	RED	ROUGE	ROT	
	25547026/0	VERDE	GREEN	VERT	GRÜN	
	25547027/0	GIALLA	YELLOW	JAUNE	GELB	
	25547028/0	BLU	BLUE	BLEU	BLAU	
11	12792099/0	VITE	SCREW	VIS	SCHRAUBE	4
12	12729601/0	VITE	SCREW	VIS	SCHRAUBE	8
13	12674701/0	VITE	SCREW	VIS	SCHRAUBE	2
14	12292100/0	DADO	NUT	ECROU	MUTTER	4
15	12582101/0	GROWER	GROWER	GROWER	GROWER	6
16	12521331/0	RONDELLA	WASHER	RONDELLE	SCHEIBE	6

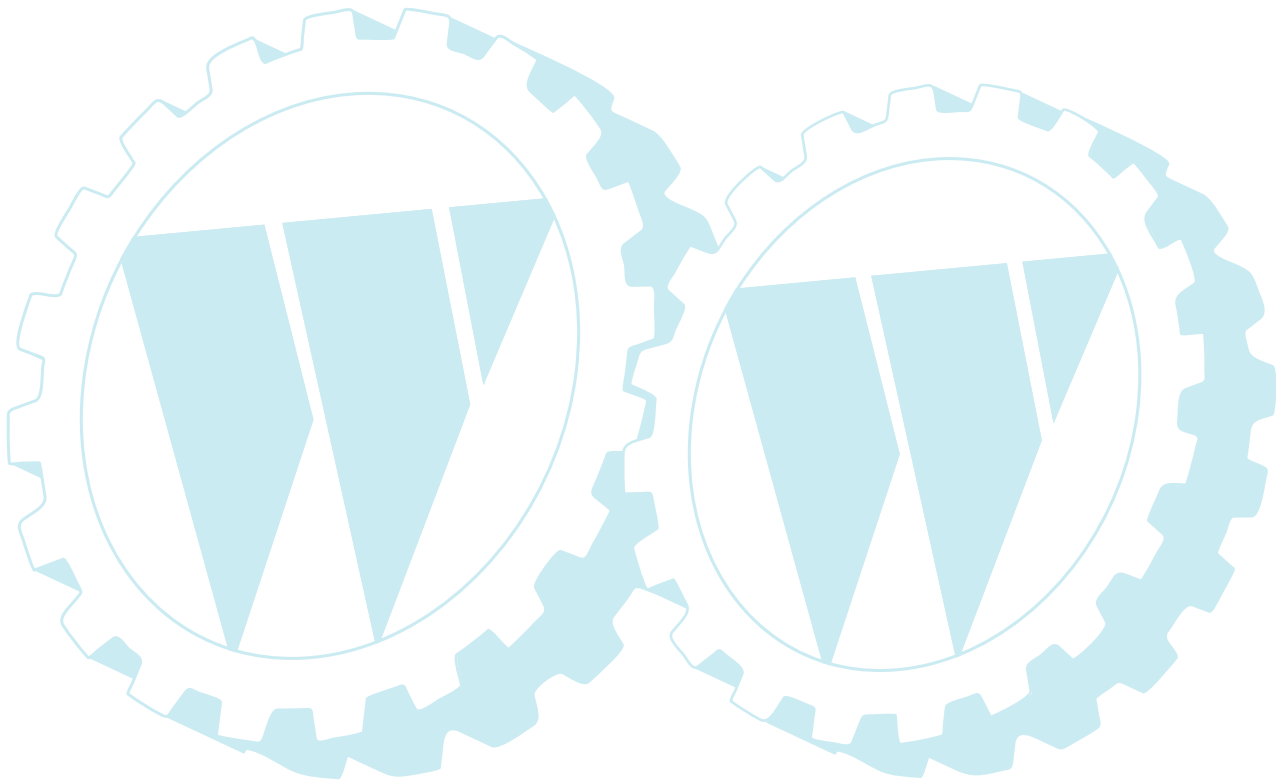

PARTI DI RICAMBIO PER IL TRATTORINO
 SPARE PARTS FOR RIDER-ON-MOWERS
 PIECES DETACHEES POUR TONDEUSE AUTOPORTEE
 RASENTRAKTORERSATZTEILE

TC(P)
TC(P) hydro

Mod. 1998

013

ACCESSORI A RICHIESTA
 OPTIONALS ON REQUEST
 ACCESSOIRES SUR DEMANDE
 ZUBEHOERE NACH ANFRAGE

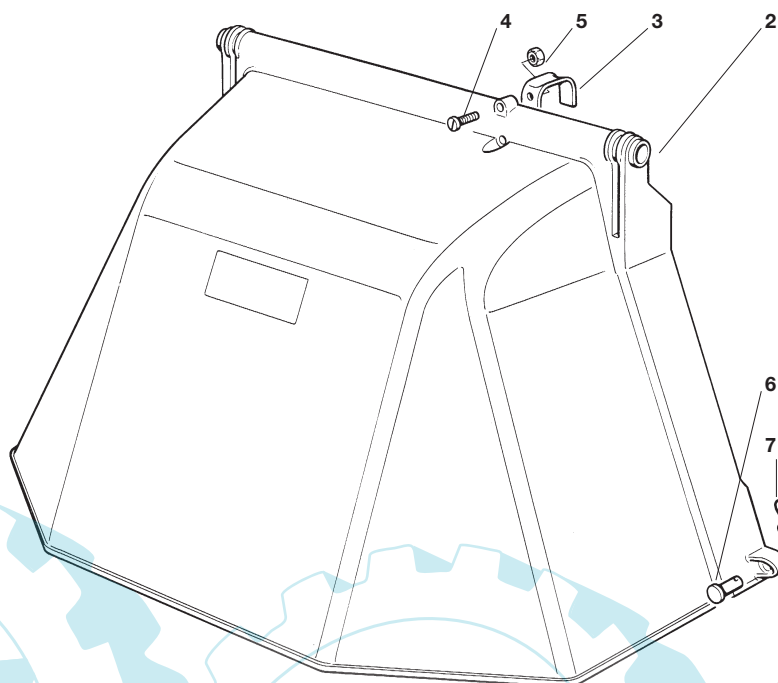
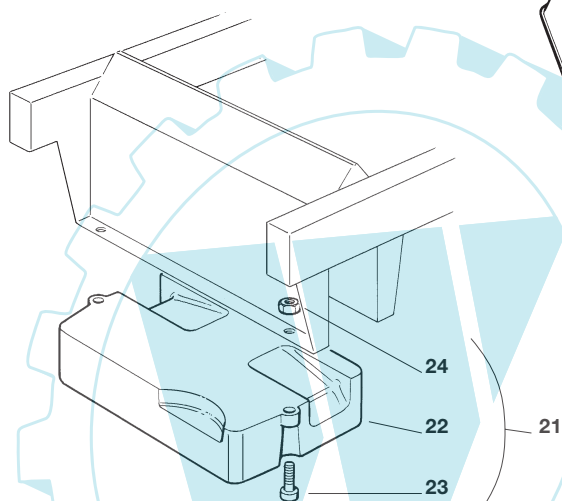
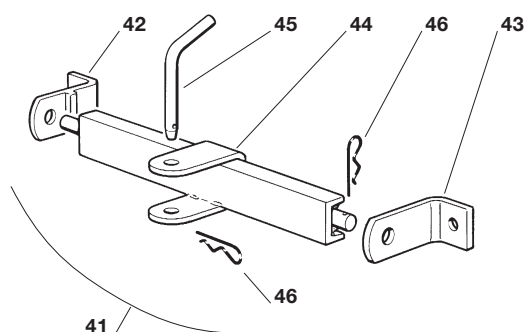

Pos. Nr.	Codice Kodex Code	Descrizione	Description	Description	Beschreibung	Q.tà Q.ty Q.té Menge
1	99900010/1	ASS. KIT PROTEZIONE USCITA	EJECTION-GUARD ASS.Y	KIT PROTECTION SORTIE	VORRICHTUNG FÜR AUSWURESCHUTZ	1
2	82400001/1	PROTEZIONE USCITA	EJECTION GUARD	PROTECTION SORTIE	AUSWURFSCHUTZ	1
3	25430216/0	MOLLA	SPRING	RESSORT	FEDER	1
4	12769100/0	VITE	SCREW	VIS	SCHRAUBE	2
5	12150000/0	DADO	NUT	ECROU	MUTTER	1
6	25510022/0	PERNO	PIN	PIVOT	BOLZEN	2
7	24487998/0	COPPIGLIA	COTTER PIN	GOUPILLE	SPLIT	2
21	99900030/2	ASS. KIT PESO ANT.	FRONT WEIGHT KIT	KIT POIDS ANTERIEUR	VORDERGEWICHT VORRICHTUNG	1
22	25519999/2	PESO	WEIGHT	POIDS	GEWICHT	1
23	12760510/0	VITE	SCREW	VIS	SCHRAUBE	3
24	12155000/0	DADO	NUT	ECROU	MUTTER	3
41	99900000/0	ASS. KIT TRAINO	HITCH KIT	KIT DE TRAINAGE	ZUGVORRICHTUNG	1
42	82735502/0	STAFFA SUPPORTO TRAINO DX	BRACKET RIGHT HITCH SUPPORT	ETRIER SUPPORT TRAINAGE DROITE	BUEGEL HALTER FÜR RECHTEN ZUG	1
43	25774213/0	STAFFA SUPPORTO TRAINO SX	BRACKET LEFT HITCH SUPPORT	ETRIER SUPPORT TRAINAGE GAUCHE	BUEGELHALTER FÜR LINKEN ZUG	1
44	82033101/0	BARRA	ROD	BARRE	STANGE	1
45	25510021/0	PERNO	PIN	PIVOT	BOLZEN	1
46	24487999/0	COPPIGLIA	COTTER PIN	GOUPILLE	SPLIT	2
-	18737950/0	TELO DI COPERTURA	CLOTH	BÂCHE	PLANE	1

SCHEMA ELETTRICO (12,5 HP B&S, 13 - 15 HP TECUMSEH)
 WIRE DIAGRAM (12,5 HP B&S, 13 - 15 HP TECUMSEH)
 SCHEMA ELECTRONIQUE (12,5 HP B&S, 13 - 15 HP TECUMSEH)
 ELEKTRISCHES SCHEMA (12,5 HP B&S, 13 - 15 HP TECUMSEH)

TC(P)

Mod. 1998

014

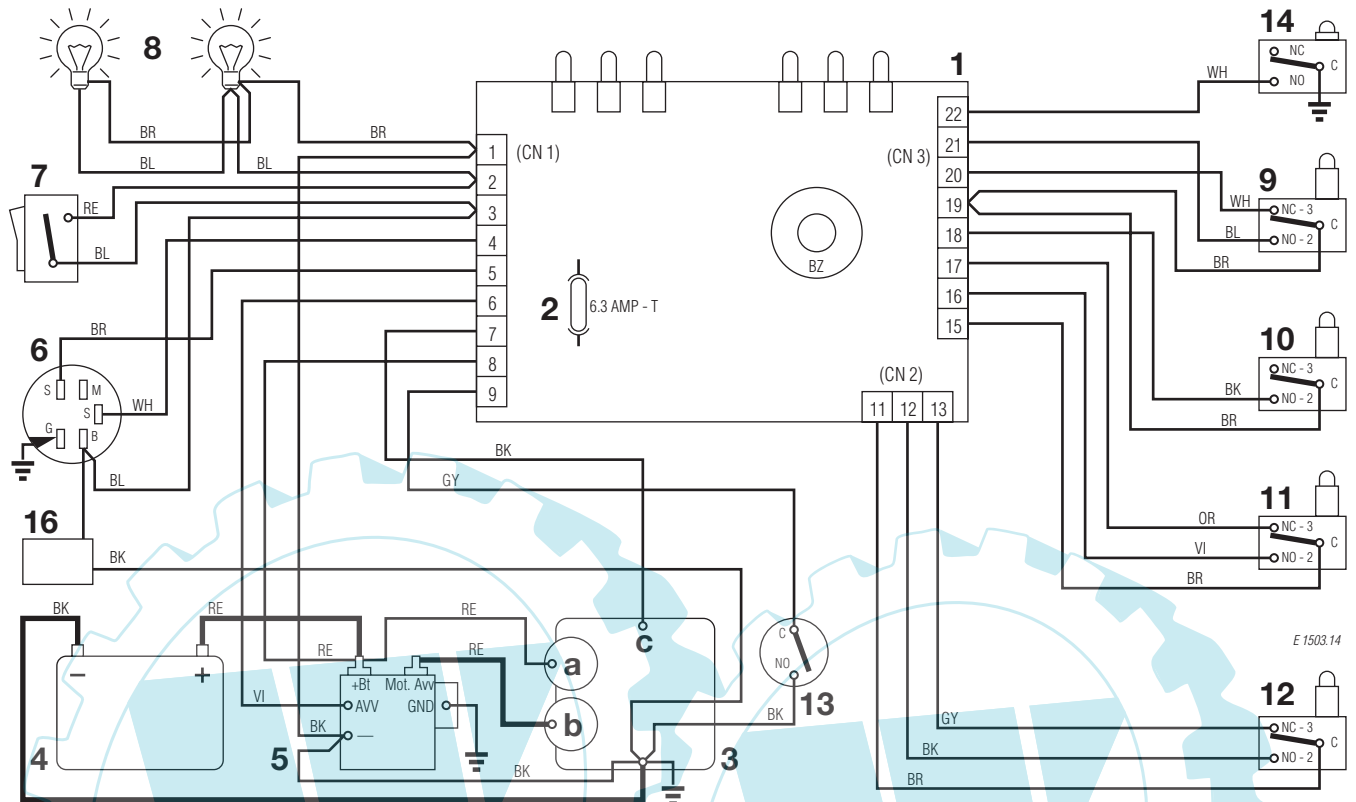

1	SCHEDA CON BUZZER	ELECTRONIC CARD WITH BUZZER	CARTE ELECTRONIQUE AVEC BUZZER	ELECTRONISCHE KARTE MIT BUZZER
2	FUSIBILE 6,3 Amp. T	FUSE 6.3 Amp. T	FUSIBLE 6,3 Amp. T	SICHERUNG 6,3 Amp. T
3	MOTORE	ENGINE	MOTEUR	MOTOR
3a	Generatore	Generator	Generateur	Generator
3b	Motorino avviamento	Starter	Demarreur	Anlasser
3c	Stop motore	Engine stop	Calage du moteur	Motor abstellung
4	BATTERIA	BATTERY	BATTERIE	BATTERIE
5	RELE AVVIAMENTO	STARTER RELAY	RELAIS DE DEMARRAGE	ANLASSER RELAIS
6	INTERRUTTORE A CHIAVE	ELECTROLOCK	INTERRUPTEUR D'ALLUMAGE	SCHLÜSSELSCHALTER
7	INTERRUTTORE FARI	HEADLIGHT SWITCH	INTERRUPTEUR PHARES	LICHTSCHALTER
8	FARI	HEADLIGHT	PHARES	LICHT
9	MICROINTERRUTTORE LAME	BLADES MICRO SWITCH	MICRO INTERRUPTEUR LAMES	MESSER MIKROSCHALTER
10	MICROINTERRUTTORE FRENO	BRAKE MICRO SWITCH	MICRO INTERRUPTEUR FREIN	BREMSE MIKROSCHALTER
11	MICROINTERRUTTORE SEDILE	SEAT MICRO SWITCH	MICRO INTERRUPTEUR SIEGE	SITZMIKROSCHALTER
12	MICROINTERRUTTORE SACCO	GRASSCATCHER MICRO SWITCH	MICRO INTERRUPTEUR BAC	GRASFANGEINRICHTUNG MIKROSCHALTER
13	MICROINTERRUTTORE CAMBIO	GERARBOX MICROSWITCH	MICRO INT. BOÎTE DE VITESSE	ANTRIEB MICROSWITCH
14	MICROINTERRUTTORE SACCO PIENO	FULL GRASSCATCHER MICRO SWITCH	MICRO BAC PLEIN	VOLLKORB VORRICHTUNG
16	CONTAORE (TCP)	HOUR COUNTER (TCP)	COMPTE-HEURS (TCP)	BETRIEBESSTUNDENZÄHLER (TCP)

COLORI CAVI

BK	NERO
BL	BLU
BR	MARRONE
GY	GRIGIO
OR	ARANCIONE
RE	ROSSO
VI	VIOLA
YG	GIALLO/VERDE
WH	BIANCO

CABLE COLOURS

BLACK
BLUE
BROWN
GREY
ORANGE
RED
VIOLET
YELLOW/GREEN
WHITE

COULEUR CABLES

NOIR
BLEU
BUN
GRIS
ORANGE
ROUGE
VIOLEY
JAUNE/VERT
BLANC

KABEL FARBEN

SCHWARZ
BLAU
BRAUN
GRAU
ORANGE
ROT
VIOLETT
GELB/GRÜN
WEISS

SCHEMA ELETTRICO (15,5 HP B&S)
 WIRE DIAGRAM (15,5 HP B&S)
 SCHEMA ELECTRONIQUE (15,5 HP B&S)
 ELEKTRISCHES SCHEMA (15,5 HP B&S)

TC(P)

Mod. 1998 **014a**

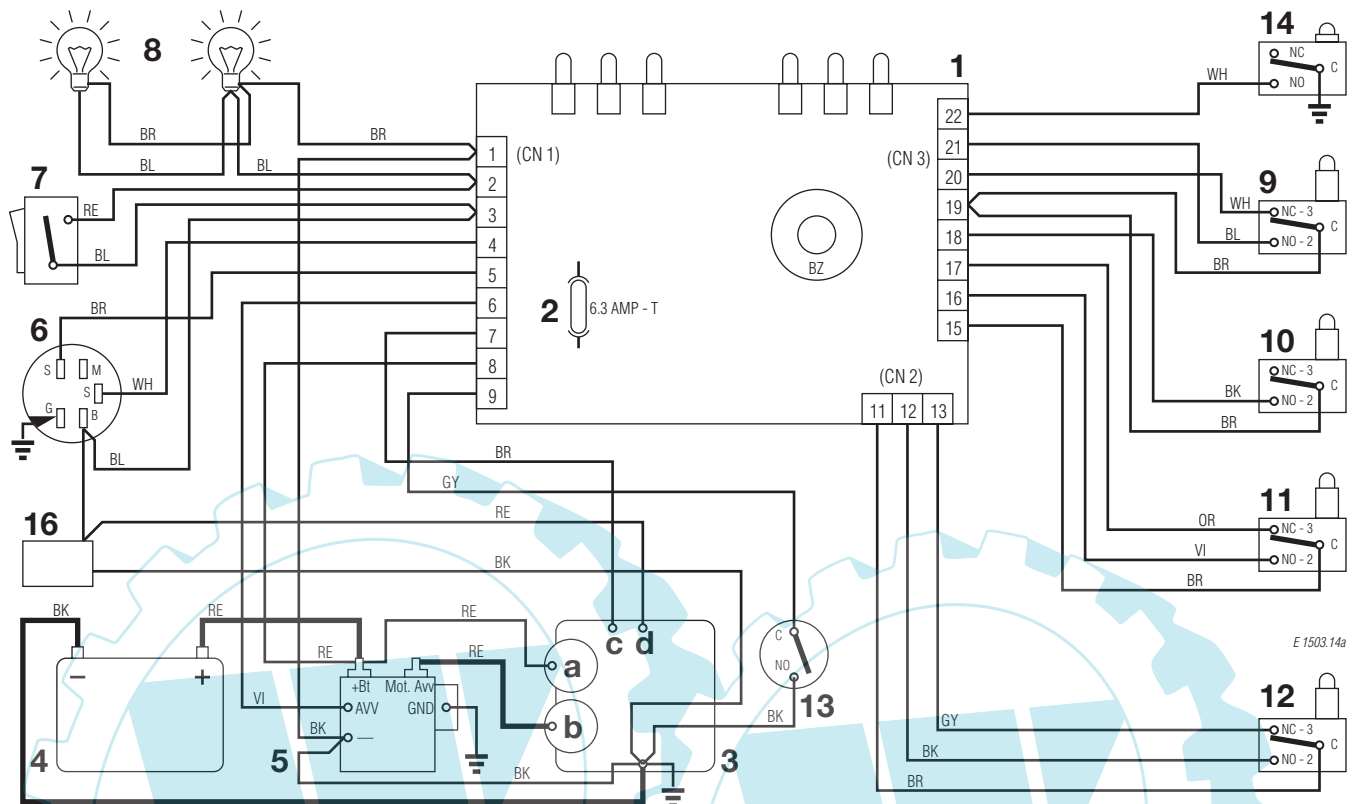

1	SCHEDA CON BUZZER	ELECTRONIC CARD WITH BUZZER	CARTE ELECTRONIQUE AVEC BUZZER	ELECTRONISCHE KARTE MIT BUZZER
2	FUSIBILE 6,3 Amp. T	FUSE 6.3 Amp. T	FUSIBLE 6,3 Amp. T	SICHERUNG 6,3 Amp. T
3	MOTORE	ENGINE	MOTEUR	MOTOR
3a	Generatore	Generator	Generateur	Generator
3b	Motorino avviamento	Starter	Demarreur	Anlasser
3c	Stop motore	Engine stop	Calage du moteur	Motor abstellung
3d	Carburatore	Carburetor	Carburateur	Vergaser
4	BATTERIA	BATTERY	BATTERIE	BATTERIE
5	RELE AVVIAMENTO	STARTER RELAY	RELAIS DE DEMARRAGE	ANLASSER RELAIS
6	INTERRUTTORE A CHIAVE	ELECTROLOCK	INTERRUPTEUR D'ALLUMAGE	SCHLÜSSELSCHALTER
7	INTERRUTTORE FARI	HEADLIGHT SWITCH	INTERRUPTEUR PHARES	LICHTSCHALTER
8	FARI	HEADLIGHT	PHARES	LICHT
9	MICROINTERRUTTORE LAME	BLADES MICRO SWITCH	MICRO INTERRUPTEUR LAMES	MESSER MIKROSCHALTER
10	MICROINTERRUTTORE FRENO	BRAKE MICRO SWITCH	MICRO INTERRUPTEUR FREIN	BREMSE MIKROSCHALTER
11	MICROINTERRUTTORE SEDILE	SEAT MICRO SWITCH	MICRO INTERRUPTEUR SIEGE	SITZMIKROSCHALTER
12	MICROINTERRUTTORE SACCO	GRASSCATCHER MICRO SWITCH	MICRO INTERRUPTEUR BAC	GRASFANGEINRICHTUNG MIKROSCHALTER
13	MICROINTERRUTTORE CAMBIO	GERARBOX MICROSWITCH	MICRO INT. BOÎTE DE VITESSE	ANTRIEB MIKROSCHALTER
14	MICROINTERRUTTORE SACCO PIENO	FULL GRASSCATCHER MICRO SWITCH	MICRO BAC PLEIN	VOLLKORB VORRICHTUNG
16	CONTAORE (TCP)	HOUR COUNTER (TCP)	COMPTE-HEURS (TCP)	BETRIEBESSTUNDENZÄHLER (TCP)

COLORI CAVI

BK	NERO
BL	BLU
BR	MARRONE
GY	GRIGIO
OR	ARANCIONE
RE	ROSSO
VI	VIOLA
YG	GIALLO/VERDE
WH	BIANCO

CABLE COLOURS

BLACK	BLACK
BLUE	BLUE
BROWN	BROWN
GREY	GREY
ORANGE	ORANGE
RED	RED
VIOLET	VIOLET
YELLOW/GREEN	YELLOW/GREEN
WHITE	WHITE

COULEUR CABLES

NOIR	NOIR
BLEU	BLEU
BUN	BUN
GRIS	GRIS
ORANGE	ORANGE
ROUGE	ROUGE
VIOLEY	VIOLEY
JAUNE/VERT	JAUNE/VERT
BLANC	BLANC

KABEL FARBEN

SCHWARZ	SCHWARZ
BLAU	BLAU
BRAUN	BRAUN
GRAU	GRAU
ORANGE	ORANGE
ROT	ROT
VIOLETT	VIOLETT
GELB/GRÜN	GELB/GRÜN
WEISS	WEISS

SCHEMA ELETTRICO (16 - 18 - 20 HP B&S)

WIRE DIAGRAM (16 - 18 - 20 HP B&S)

SCHEMA ELECTRONIQUE (16 - 18 - 20 HP B&S)

ELEKTRISCHES SCHEMA (16 - 18 - 20 HP B&S)

TC(P)

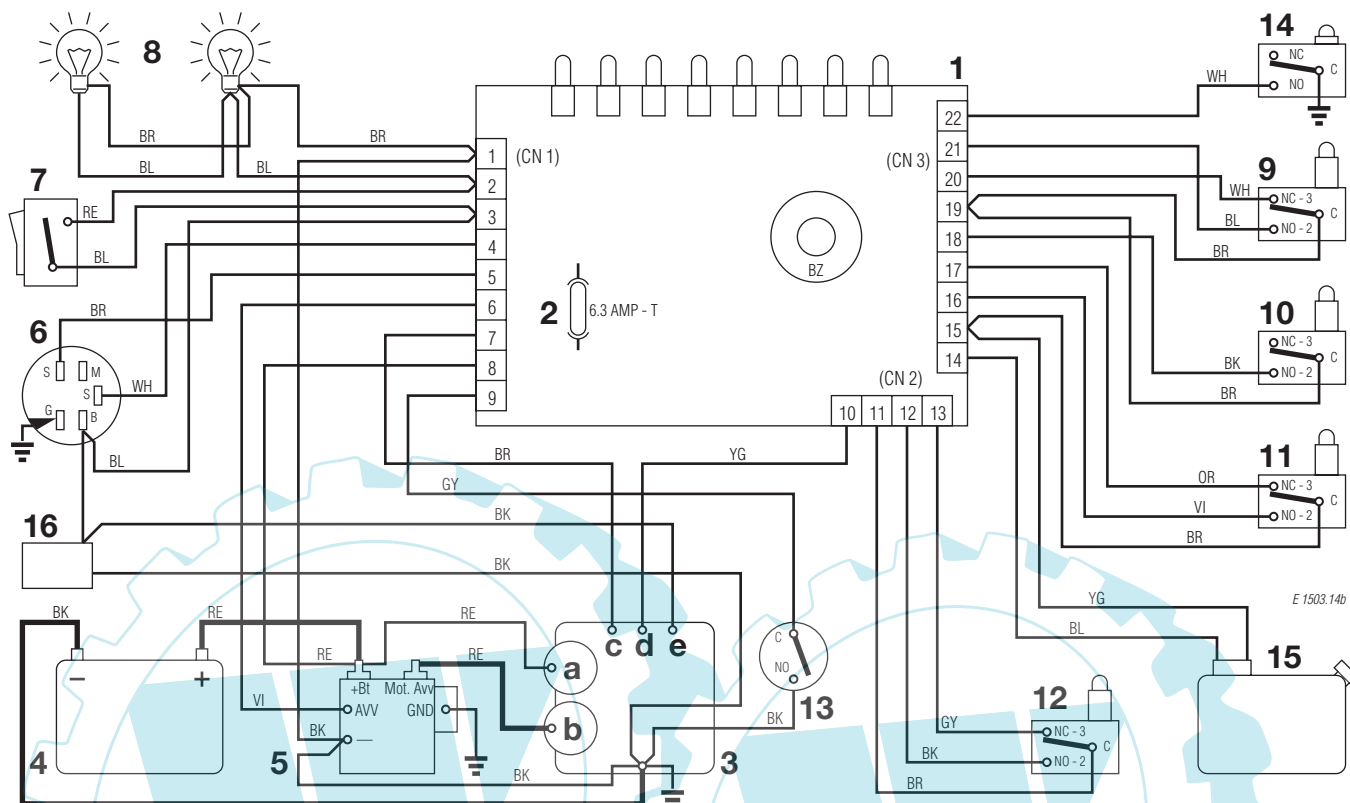
Mod. 1998 **014b**

1	SCHEDA CON BUZZER	ELECTRONIC CARD WITH BUZZER	CARTE ELECTRONIQUE AVEC BUZZER	ELECTRONISCHE KARTE MIT BUZZER
2	FUSIBILE 6,3 Amp. T	FUSE 6.3 Amp. T	FUSIBLE 6,3 Amp. T	SICHERUNG 6,3 Amp. T
3	MOTORE	ENGINE	MOTEUR	MOTOR
3a	Generatore	Generator	Genérateur	Generator
3b	Motorino avviamento	Starter	Demarreur	Anlasser
3c	Stop motore	Engine stop	Calage du moteur	Motor abstellung
3d	Olio	Oil	Huile	Öl
3e	Carburatore	Carburetor	Carburateur	Vergaser
4	BATTERIA	BATTERY	BATTERIE	BATTERIE
5	RELE AVVIAMENTO	STARTER RELAY	RELAIS DE DEMARRAGE	ANLASSER RELAIS
6	INTERRUTTORE A CHIAVE	ELECTROLOCK	INTERRUPTEUR D'ALLUMAGE	SCHLÜSSELSCHALTER
7	INTERRUTTORE FARI	HEADLIGHT SWITCH	INTERRUPTEUR PHARES	LICHTSCHALTER
8	FARI	HEADLIGHT	PHARES	LICHT
9	MICROINTERRUTTORE LAME	BLADES MICRO SWITCH	MICRO INTERRUPTEUR LAMES	MESSER MIKROSCHALTER
10	MICROINTERRUTTORE FRENO	BRAKE MICRO SWITCH	MICRO INTERRUPTEUR FREIN	BREMSE MIKROSCHALTER
11	MICROINTERRUTTORE SEDILE	SEAT MICRO SWITCH	MICRO INTERRUPTEUR SIEGE	SITZMIKROSCHALTER
12	MICROINTERRUTTORE SACCO	GRASSCATCHER MICRO SWITCH	MICRO INTERRUPTEUR BAC	GRASFANGEINRICHTUNG MIKROSCHALTER
13	MICROINTERRUTTORE CAMBIO	GERARBOX MICROSWITCH	MICRO INT. BOÎTE DE VITESSE	ANTRIEB MICROSWITCHALTER
14	MICROINTERRUTTORE SACCO PIENO	FULL GRASSCATCHER MICRO SWITCH	MICRO BAC PLEIN	VOLLKORB VORRICHTUNG
15	SERBATOIO	TANK	RESERVIOR	TANK
16	CONTAORE (TCP)	HOUR COUNTER (TCP)	COMPTE-HEURS (TCP)	BETRIEBESSTUNDENZÄHLER (TCP)

COLORI CAVI

BK	NERO
BL	BLU
BR	MARRONE
GY	GRIGIO
OR	ARANCIONE
RE	ROSSO
VI	VIOLA
YG	GIALLO/VERDE
WH	BIANCO

CABLE COLOURS

BLACK
BLUE
BROWN
GREY
ORANGE
RED
VIOLET
YELLOW/GREEN
WHITE

COULEUR CABLES

NOIR
BLEU
BUN
GRIS
ORANGE
ROUGE
VIOLEY
JAUNE/VERT
BLANC

KABEL FARBEN

SCHWARZ
BLAU
BRAUN
GRAU
ORANGE
ROT
VIOLETT
GELB/GRÜN
WEISS

SCHEMA ELETTRICO (12,5 HP B&S, 13 - 15 HP TECUMSEH)
 WIRE DIAGRAM (12,5 HP B&S, 13 - 15 HP TECUMSEH)
 SCHEMA ELECTRONIQUE (12,5 HP B&S, 13 - 15 HP TECUMSEH)
 ELEKTRISCHES SCHEMA (12,5 HP B&S, 13 - 15 HP TECUMSEH)

TC(P) hydro

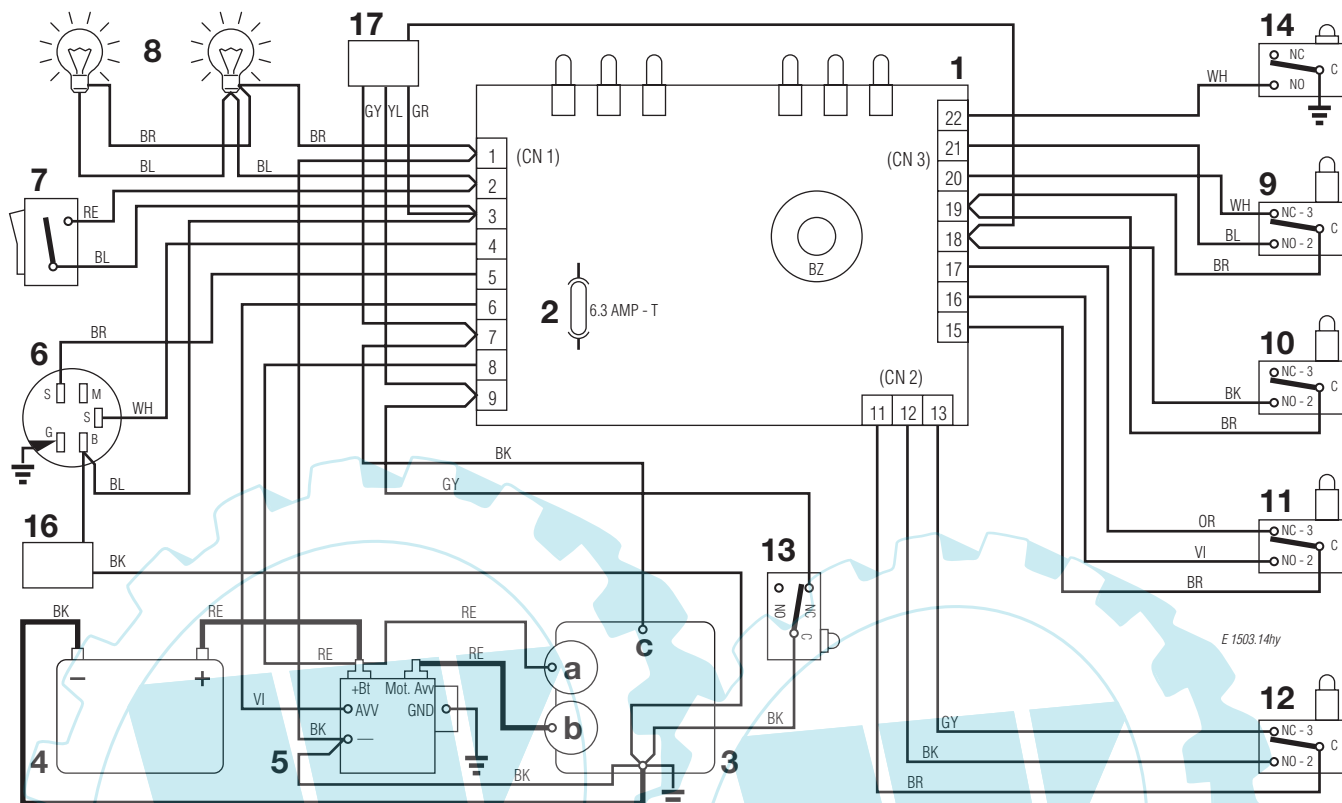
 Mod. 1998 **014.1**

1	SCHEDA CON BUZZER	ELECTRONIC CARD WITH BUZZER	CARTE ELECTRONIQUE AVEC BUZZER	ELECTRONISCHE KARTE MIT BUZZER
2	FUSIBILE 6,3 Amp. T	FUSE 6.3 Amp. T	FUSIBLE 6,3 Amp. T	SICHERUNG 6,3 Amp. T
3	MOTORE	ENGINE	MOTEUR	MOTOR
3a	Generatore	Generator	Generateur	Generator
3b	Motorino avviamento	Starter	Demarreur	Anlasser
3c	Stop motore	Engine stop	Calage du moteur	Motor abstellung
4	BATTERIA	BATTERY	BATTERIE	BATTERIE
5	RELE AVVIAMENTO	STARTER RELAY	RELAIS DE DEMARRAGE	ANLASSER RELAIS
6	INTERRUTTORE A CHIAVE	ELECTROLOCK	INTERRUPTEUR D'ALLUMAGE	SCHLÜSSELSCHALTER
7	INTERRUTTORE FARI	HEADLIGHT SWITCH	INTERRUPTEUR PHARES	LICHTSCHALTER
8	FARI	HEADLIGHT	PHARES	LICHT
9	MICROINTERRUTTORE LAME	BLADES MICRO SWITCH	MICRO INTERRUPTEUR LAMES	MESSER MIKROSCHALTER
10	MICROINTERRUTTORE FRENO	BRAKE MICRO SWITCH	MICRO INTERRUPTEUR FREIN	BREMSE MIKROSCHALTER
11	MICROINTERRUTTORE SEDILE	SEAT MICRO SWITCH	MICRO INTERRUPTEUR SIEGE	SITZMIKROSCHALTER
12	MICROINTERRUTTORE SACCO	GRASSCATCHER MICRO SWITCH	MICRO INTERRUPTEUR BAC	GRASFANGANRICHTUNG MIKROSCHALTER
13	MICROINTERRUTTORE FOLLE	NEUTRAL MICROSWITCH	MICRO INT. POINT MORT	LEERLAUF MICROSWITCH
14	MICROINTERRUTTORE SACCO PIENO	FULL GRASSCATCHER MICRO SWITCH	MICRO BAC PLEIN	VOLLKORB VORRICHTUNG
16	CONTAORE (TCP)	HOUR COUNTER (TCP)	COMPTE-HEURS (TCP)	BETRIEBESSTUNDENZÄHLER (TCP)
17	INTERFACCIA	INTERFACE	INTERFACE	INTERFACE

COLORI CAVI

BK	NERO
BL	BLU
BR	MARRONE
GY	GRIGIO
GR	VERDE
OR	ARANCIONE
RE	ROSSO
VI	VIOLA
YG	GIALLO/VERDE
YL	GIALLO
WH	BIANCO

CABLE COLOURS

BLACK
BLUE
BROWN
GREY
GREEN
ORANGE
RED
VIOLET
YELLOW/GREEN
YELLOW
WHITE

COULEUR CABLES

NOIR
BLEU
BUN
GRIS
VERT
ORANGE
ROUGE
VIOLEY
JAUNE/VERT
JAUNE
BLANC

KABEL FARBEN

SCHWARZ
BLAU
BRAUN
GRAU
GRÜN
ORANGE
ROT
VIOLETT
GELB/GRÜN
GELB
WEISS

SCHEMA ELETTRICO (15,5 HP B&S)
 WIRE DIAGRAM (15,5 HP B&S)
 SCHEMA ELECTRONIQUE (15,5 HP B&S)
 ELEKTRISCHES SCHEMA (15,5 HP B&S)

TC(P) hydro

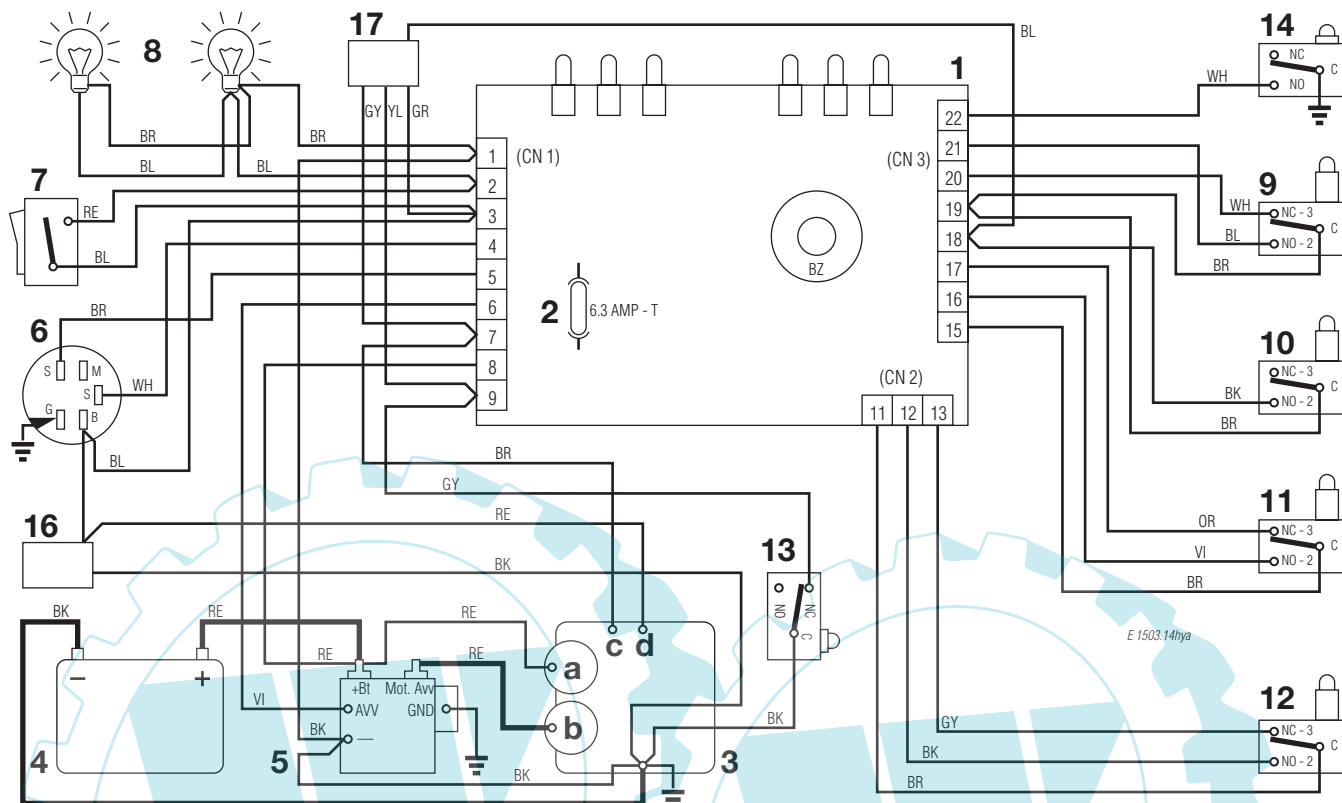
 Mod. 1998 **014a.1**

E 1503.141ya

1	SCHEDA CON BUZZER	ELECTRONIC CARD WITH BUZZER	CARTE ELECTRONIQUE AVEC BUZZER	ELECTRONISCHE KARTE MIT BUZZER
2	FUSIBILE 6,3 Amp. T	FUSE 6.3 Amp. T	FUSIBLE 6,3 Amp. T	SICHERUNG 6,3 Amp. T
3	MOTORE	ENGINE	MOTEUR	MOTOR
3a	Generatore	Generator	Generateur	Generator
3b	Motorino avviamento	Starter	Demarreur	Anlasser
3c	Stop motore	Engine stop	Calage du moteur	Motor abstellung
3d	Carburatore	Carburetor	Carburateur	Vergaser
4	BATTERIA	BATTERY	BATTERIE	BATTERIE
5	RELE AVVIAMENTO	STARTER RELAY	RELAIS DE DEMARRAGE	ANLASSER RELAIS
6	INTERRUTTORE A CHIAVE	ELECTROLOCK	INTERRUPTEUR D'ALLUMAGE	SCHLÜSSELSCHALTER
7	INTERRUTTORE FARI	HEADLIGHT SWITCH	INTERRUPTEUR PHARES	LICHTSCHALTER
8	FARI	HEADLIGHT	PHARES	LICHT
9	MICROINTERRUTTORE LAME	BLADES MICRO SWITCH	MICRO INTERRUPTEUR LAMES	MESSER MIKROSCHALTER
10	MICROINTERRUTTORE FRENO	BRAKE MICRO SWITCH	MICRO INTERRUPTEUR FREIN	BREMSE MIKROSCHALTER
11	MICROINTERRUTTORE SEDILE	SEAT MICRO SWITCH	MICRO INTERRUPTEUR SIEGE	SITZMIKROSCHALTER
12	MICROINTERRUTTORE SACCO	GRASSCATCHER MICRO SWITCH	MICRO INTERRUPTEUR BAC	GRASFANGEINRICHTUNG MIKROSCHALTER
13	MICROINTERRUTTORE FOLLE	NEUTRAL MICROSWITCH	MICRO INT. POINT MORT	LEERLAUF MICROSCHALTER
14	MICROINTERRUTTORE SACCO PIENO	FULL GRASSCATCHER MICRO SWITCH	MICRO BAC PLEIN	VOLLKORB VORRICHTUNG
16	CONTAORE (TCP)	HOUR COUNTER (TCP)	COMPTE-HEURS (TCP)	BETRIEBESSTUNDENZÄHLER (TCP)
17	INTERFACCIA	INTERFACE	INTERFACE	INTERFACE

COLORI CAVI

BK	NERO
BL	BLU
BR	MARRONE
GY	GRIGIO
GR	VERDE
OR	ARANCIONE
RE	ROSSO
VI	VIOLA
YG	GIALLO/VERDE
YL	GIALLO
WH	BIANCO

CABLE COLOURS

BLACK
BLUE
BROWN
GREY
GREEN
ORANGE
RED
VIOLET
YELLOW/GREEN
YELLOW
WHITE

COULEUR CABLES

NOIR
BLEU
BUN
GRIS
VERT
ORANGE
ROUGE
VIOLEY
JAUNE/VERT
JAUNE
BLANC

KABEL FARBEN

SCHWARZ
BLAU
BRAUN
GRAU
GRÜN
ORANGE
ROT
VIOLETT
GELB/GRÜN
GELB
WEISS

SCHEMA ELETTRICO (16 - 18 - 20 HP B&S)

WIRE DIAGRAM (16 - 18 - 20 HP B&S)

SCHEMA ELECTRONIQUE (16 - 18 - 20 HP B&S)

ELEKTRISCHES SCHEMA (16 - 18 - 20 HP B&S)

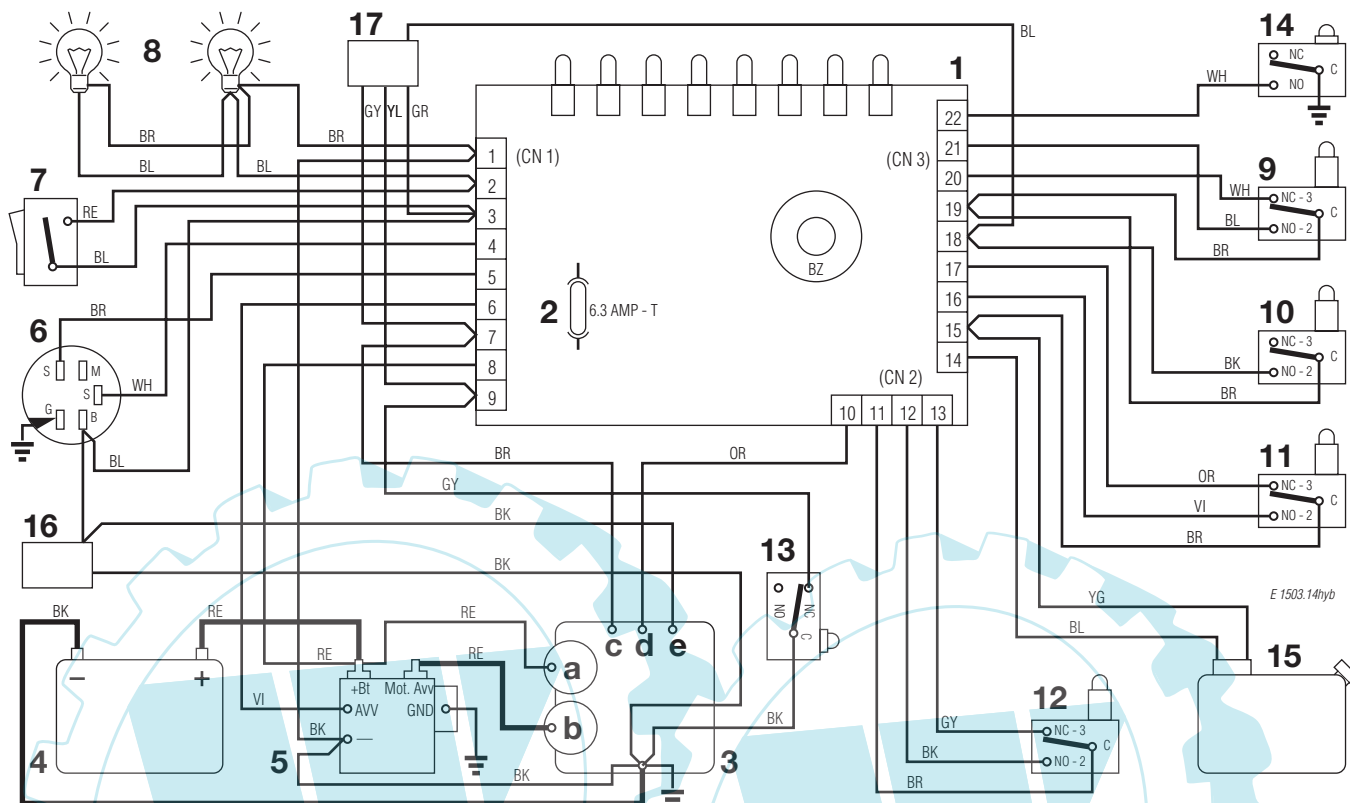
TC(P) hydroMod. 1998 **014b.1**

1	SCHEDA CON BUZZER	ELECTRONIC CARD WITH BUZZER	CARTE ELECTRONIQUE AVEC BUZZER	ELECTRONISCHE KARTE MIT BUZZER
2	FUSIBILE 6,3 Amp. T	FUSE 6.3 Amp. T	FUSIBLE 6,3 Amp. T	SICHERUNG 6,3 Amp. T
3	MOTORE	ENGINE	MOTEUR	MOTOR
3a	Generatore	Generator	Generateur	Generator
3b	Motorino avviamento	Starter	Demarreur	Anlasser
3c	Stop motore	Engine stop	Calage du moteur	Motor abstellung
3d	Olio	Oil	Huile	Öl
3e	Carburatore	Carburetor	Carburateur	Vergaser
4	BATTERIA	BATTERY	BATTERIE	BATTERIE
5	RELE AVVIAMENTO	STARTER RELAY	RELAIS DE DEMARRAGE	ANLASSER RELAIS
6	INTERRUTTORE A CHIAVE	ELECTROLOCK	INTERRUPTEUR D'ALLUMAGE	SCHLÜSSELSCHALTER
7	INTERRUTTORE FARI	HEADLIGHT SWITCH	INTERRUPTEUR PHARES	LICHTSCHALTER
8	FARI	HEADLIGHT	PHARES	LICHT
9	MICROINTERRUTTORE LAME	BLADES MICRO SWITCH	MICRO INTERRUPTEUR LAMES	MESSER MIKROSCHALTER
10	MICROINTERRUTTORE FRENO	BRAKE MICRO SWITCH	MICRO INTERRUPTEUR FREIN	BREMSE MIKROSCHALTER
11	MICROINTERRUTTORE SEDILE	SEAT MICRO SWITCH	MICRO INTERRUPTEUR SIEGE	SITZMIKROSCHALTER
12	MICROINTERRUTTORE SACCO	GRASSCATCHER MICRO SWITCH	MICRO INTERRUPTEUR BAC	GRASFANGEINRICHTUNG MIKROSCHALTER
13	MICROINTERRUTTORE FOLLE	NEUTRAL MICROSWITCH	MICRO INT. POINT MORT	LEERLAUF MICROSWITCHER
14	MICROINTERRUTTORE SACCO PIENO	FULL GRASSCATCHER MICRO SWITCH	MICRO BAC PLEIN	VOLLKORB VORRICHTUNG
16	CONTAORE (TCP)	HOUR COUNTER (TCP)	COMPTE-HEURS (TCP)	BETRIEBESSTUNDENZÄHLER (TCP)
17	INTERFACCIA	INTERFACE	INTERFACE	INTERFACE

COLORI CAVI

BK	NERO
BL	BLU
BR	MARRONE
GY	GRIGIO
GR	VERDE
OR	ARANCIONE
RE	ROSSO
VI	VIOLA
YG	GIALLO/VERDE
YL	GIALLO
WH	BIANCO

CABLE COLOURS

BLACK
BLUE
BROWN
GREY
GREEN
ORANGE
RED
VIOLET
YELLOW/GREEN
YELLOW
WHITE

COULEUR CABLES

NOIR
BLEU
BUN
GRIS
VERT
ORANGE
ROUGE
VIOLEY
JAUNE/VERT
JAUNE
BLANC

KABEL FARBEN

SCHWARZ
BLAU
BRAUN
GRAU
GRÜN
ORANGE
ROT
VIOLETT
GELB/GRÜN
GELB
WEISS